



LADA

4x4

SERVICE BOOK



User manual
for
LADA 4x4
and its versions

TABLE OF CONTENTS

<p>FOR USER'S ATTENTION 3</p> <p>DESCRIPTION OF THE CAR 6</p> <p style="padding-left: 20px;">Car keys 6</p> <p style="padding-left: 20px;">Doors 7</p> <p style="padding-left: 20px;">Fuel tank plug 8</p> <p style="padding-left: 20px;">Bonnet/hood 9</p> <p style="padding-left: 20px;">Pedal location area 9</p> <p style="padding-left: 20px;">Seats 10</p> <p style="padding-left: 20px;">Mounting of child restraint system 11</p> <p style="padding-left: 20px;">Seat belts 13</p> <p style="padding-left: 20px;">Sun visors and mirrors 14</p> <p style="padding-left: 20px;">Hydraulic power steering 14</p> <p style="padding-left: 20px;">VAZ-2131 car model and its modifications 15</p> <p style="padding-left: 20px;">Car controls 17</p> <p style="padding-left: 20px;">Instrument cluster 19</p> <p style="padding-left: 20px;">Under-steering-wheel switches ... 22</p> <p style="padding-left: 20px;">Glove box 23</p> <p style="padding-left: 20px;">Ash tray 23</p> <p>CAR OPERATION 24</p> <p style="padding-left: 20px;">Licence plate mounting 24</p> <p style="padding-left: 20px;">Ignition switch 24</p> <p style="padding-left: 20px;">Engine start 25</p> <p style="padding-left: 20px;">Electronic antitheft system 26</p> <p style="padding-left: 20px;">Arrangement of transfer case levers 30</p> <p style="padding-left: 20px;">Car movement 30</p>	<p>Braking and parking 32</p> <p>Car towing 33</p> <p>Operation of a new car 33</p> <p>Safety precautions in car operation . 34</p> <p>ECU-equipped car operation features 35</p> <p>Passenger compartment ventilation and heating control 38</p> <p>Interior lighting 39</p> <p>LADA 4x4 Urban VEHICLE VERSION 39</p> <p style="padding-left: 20px;">Vehicle description 39</p> <p>INTERIOR EQUIPMENT 39</p> <p style="padding-left: 20px;">Interior lamp 39</p> <p style="padding-left: 20px;">Outer mirrors with electric drive .. 39</p> <p style="padding-left: 20px;">Glass holder 40</p> <p style="padding-left: 20px;">Window lifters 40</p> <p style="padding-left: 20px;">Steering wheel with modified design 41</p> <p style="padding-left: 20px;">Vehicle towing 41</p> <p style="padding-left: 20px;">Spare wheel 42</p> <p style="padding-left: 20px;">Exterior dimensions for LADA 4x4 Urban 43</p> <p style="padding-left: 20px;">Type and nominal amount of coolant in conditioner 44</p> <p style="padding-left: 20px;">Refit of fuses 44</p> <p style="padding-left: 20px;">Additional circuits, protected by fuses 44</p> <p>CAR MAINTENANCE AND ROUTINE REPAIRS 45</p> <p style="padding-left: 20px;">Crankcase oil level 45</p> <p style="padding-left: 20px;">Coolant level 46</p>	<p>Brake fluid level 47</p> <p>Hydraulic power steering 48</p> <p>Battery electrolyte level 49</p> <p>Spark plugs and other ignition system elements 50</p> <p>Washing fluids 50</p> <p>Tire servicing 51</p> <p>Wheels Changing 52</p> <p>Replacing lamp 53</p> <p>Replacement of fuses 55</p> <p>Body 58</p> <p>Car laying-up 60</p> <p>CAR PERFORMANCE DATA 61</p> <p style="padding-left: 20px;">Main performance parameters and dimensions 61</p> <p style="padding-left: 20px;">Main engine parameters 64</p> <p style="padding-left: 20px;">Car fuel and speed performance data 64</p> <p style="padding-left: 20px;">Charge volumes 65</p> <p style="padding-left: 20px;">Passport details 66</p> <p>APPENDICES 68</p> <p style="padding-left: 20px;">1. Oil and lubricants validated and recommended for operation of LADA 4x4 car and its versions .. 68</p> <p style="padding-left: 20px;">2. Lamps used in the car 78</p> <p style="padding-left: 20px;">3. List of parts containing precious metals used in LADA 4x4 car 79</p> <p style="padding-left: 20px;">4. Spark plugs 80</p>
---	---	---

FOR USER'S ATTENTION

Before you start operating your car please study carefully the present operation manual which presents information on its design features, its controls, equipment as well as safety requirements and rules of usage.

The car has high dynamic qualities, so in initial period of its operation, irrespective of your driving experience, we recommend you to exercise caution until you have completely mastered techniques of driving this car.

The car is designed for transportation of passengers and luggage (in quantity and weight declared by the manufacturer) at ambient temperature of -40 °C...+45 °C on public roads with hard pavement conforming to GOST R 50597 requirements. In case of need to drive on macadam or bumpy and wavy roads it is necessary to select an operation condition that would ensure integrity of body protection coatings and security from damages, impacts of crushed stone flying out from under the wheels, sharp blows of suspension

and strong torsional loads on the car body.

The car complies with Russian Federation requirements set to product quality performance and its safety. Conformity of the car to these requirements has been certified by appropriate authorized RF bodies by issuance of «Vehicle Type Approval» the number of which is indicated on summary manufacturer's data plate.

Bear in mind that any factory marking, identification tags and labels on parts and units of your car shall be maintained up to the end of service life, otherwise, the manufacturer (its authorized person) reserves the right to refuse to satisfy owner's claims for repair or replacement of defective part or unit.

When operating the car prevent any car damages including mechanical, chemical, thermal and other external impacts as well as road accidents as these damages affect general technical state of the car, its operation safety and consumer properties and possibility to use it

according to its designed purpose throughout the service life set by the car manufacturer.

Adequacy to designed purpose and compliance of the car with consumer properties during service life set by car manufacturer is ensured through a system of measures applied in respect of storage, operation, maintenance and technical service recommended by the manufacturer.

Bear in mind that RF Federal Law «On Traffic Safety» imposes a duty on you in respect of maintaining the car in good order; in view of this we remind you of your duty to carry out, dully and fully, all scheduled maintenance work specified in the service book attached to each car as well as all necessary running repairs.

Maintenance, repair and installation of additional equipment shall be implemented in enterprises of LADA dealer.

LADA dealer employ car service repair and disposal developed in JSC AVTOVAZ and are furnished with necessary special equipment and tools. LADA dealer enterprises have a list of additional equipment and specially

designed processes of its assembly validated by JSC AVTOVAZ.

To maintain warranty valid, installation and removal of any additional equipment should be carried out in LADA dealer enterprises with a mandatory mark made in the Service Book.

Timely execution of scheduled maintenance and repair work is essential for car technical condition, ensures designed durability and performance of the car. Once the car has undergone technical service, please ensure that the LADA dealer personnel that carried it out have entered appropriate marks in Service Book.

When operation and servicing the car please apply materials the list of which is specified herein. **Please note that the car engine with fuel injection and catalytic converter is only designed for the use of unleaded gasoline!**

The manufacturer plant bears no responsibility for units broken down due to the use of bad quality gasoline. Replacement or modification of engine ECU (EMS) software or hardware must be done in an enterprise of LADA dealer with a mandatory mark entered in «Special marks»

section of Service Book. Installation of any additional devices on the car must be done in LADA dealer enterprises with a mandatory mark entered in «Special marks» section of Service Book. Otherwise, JSC AVTOVAZ bears no responsibility for any implications that might arise after installation of additional devices.

Oil consumption value limit is 0.7 L per 1000 km mileage. This is maximum value which is indicative of engine parts wear and the need to carry out repair.

Always remember that safety of you and other road traffic participants, environmental condition and also ensuring of high performance and service life of your car stated by the manufacturer depend on its technical serviceability and your respect of car operation rules set forth in the present manual and Service Book!

The «**Warning**» and «**Attention**» headings inform you of conditions that might lead to injuring of people or damage of your car. The «**Warning**» heading means that wrong actions may lead to injuring of people, «**Attention**» – wrong actions may lead to damage of your car.

The engine of the car has been charged at the manufacturer plant with oil viscosity class according to SAE 10W-30 designed for operation in ambient temperature conditions of minus 25 °C to plus 25 °C. If a new car is to be operated also outside of the above temperature range it is necessary to change the oil for that recommended in Appendix 1 without waiting for the scheduled replacement time according to service Book. In this case repeated oil change at 2000–3000 km mileage is not required.

Car design is being continuously improved; therefore, separate units and parts and also design versions and specification packages may slightly differ from those described herein. You can obtain detailed information about your car from the seller.

With respect to new cars acquired abroad, likewise those imported to Russian Federation for sales and sold to natural and legal persons, warranty obligations of the manufacturer on Russian Federation territory are not applicable.

Technical service and repair of imported cars is carried out by the seller or an authorized enterprise of LADA dealer enterprise at

the customer's expense. Car export version features are as follows:

- vehicle certificate (PTS) is issued by RF customs bodies, it contains no relevant company details and a stamp of JSC AVTOVAZ as an organization issuing PTS;

- identification plate attached in the engine bay is containing data in English;

- warranty coupon of JSC AVTOVAZ is not available;

- other distinctive features may take place related to national requirements of importer country.

DESCRIPTION OF THE CAR

CAR KEYS

Each car is completed with a set of keys each one containing (Fig. 1) two keys: the longer ones – for ignition switch, the short ones – for door latches. Ignition key number is applied on the flag of the ring holding the keys. Having removed the flag you can keep secrecy of ignition key number.

For car specification package completed with electronic antitheft system (immobilizer*), additional 3 code keys are attached:

- two black ones – working keys and one red – a teaching (programming) key.

*Immobilizer disables engine start if key code has not been preliminarily read which ensures additional protection of the car from unauthorized use.

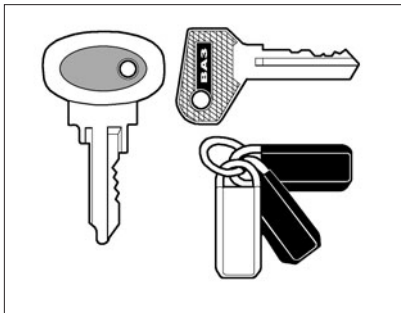

Fig. 1. Car keys

DOORS

From outside, the doors are opened by pressing the handle upwards (Fig. 2). When opening the doors courtesy light automatically switches on. The doors are furnished with a switch 1 of outside door lock. From inside, the latch is locked by pressing a latch lock button 4 (Fig. 3). The button must not be pressed when the door is open as it leads to damage of the locking device. The door is opened from inside by pulling of the lever 3 irrespective of locking button position.

The doors are furnished with a comfortable armrest 5. Drop window 2 is raised and lowered by rotation of window regulating lever 1.

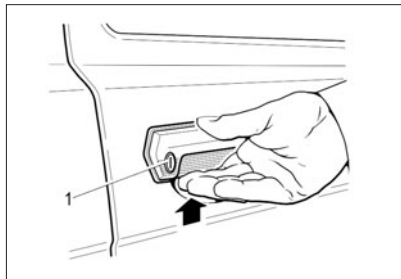

Fig. 2. Opening of doors

Trunk compartment door (tailgate)

To open trunk compartment door pull lever 1 (Fig. 4) of latch drive and then lift the tailgate up by handle 4. The tailgate is held in open position with gas-filled telescopic stops/supports 3. The trunk compartment is partitioned from the passenger compartment with shelf 2 which may be used in transport position for placement of light items.

ATTENTION!

Hood and tailgate are source of high hazard.

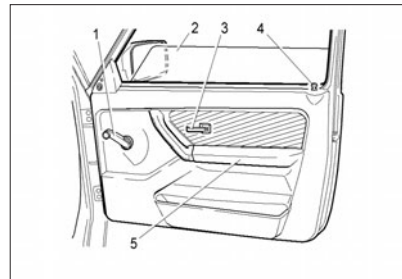
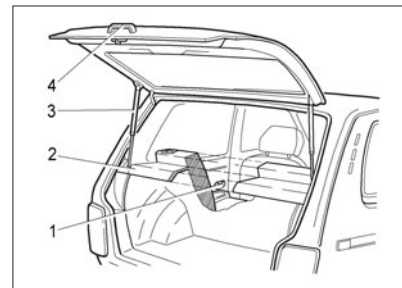

Fig. 3. Car door



**Fig. 4. Tailgate –
trunk compartment door**

When closing them you should be extremely careful especially when children are nearby.

FUEL TANK PLUG

To access the fuel tank plug 1 (Fig. 5) you should open the lid 2 located on the right side of the car body. The plug is opened by rotating it anticlockwise. The plug is screwed back in by rotating it clockwise until occurrence of distinctive clicking noises.

The flexible laisse prevents losing of the plug when filling up the car and prevents lid closing if the plug has not been screwed in fuel tank filler.

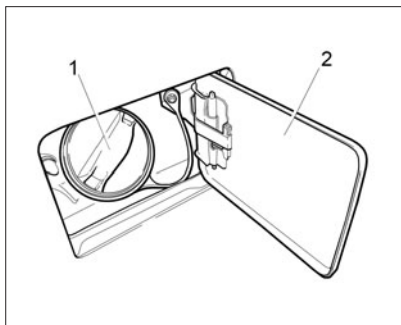

Fig. 5. Fuel tank plug

WARNING!

Gasoline as well as its vapour is poisonous and highly flammable! Observe measures of precaution and fire safety rules! Avoid skin and clothes exposure to gasoline and respiratory tract to gasoline vapour. When filling up the car avoid ingress of gasoline to paint coatings and rubber items.

Car fuel tank refueling is inadmissible after automatic filling valve cutoff or after appearance of gasoline in fuel tank filler when filling with a tap not equipped with automatic cutoff system.

Nonobservance of this recommendation may cause spillage of gasoline excesses when the car is parked.

BONNET/HOOD

To access engine compartment pull lever 1 (Fig. 6) and then open the bonnet 3 (Fig. 7) so that its stay 2 enters bracket limiter 1. When closing the bonnet, lift it slightly, withdraw the bonnet stay from bracket limiter and smoothly lower the bonnet. Press the bonnet in the latch area until the latch snaps.

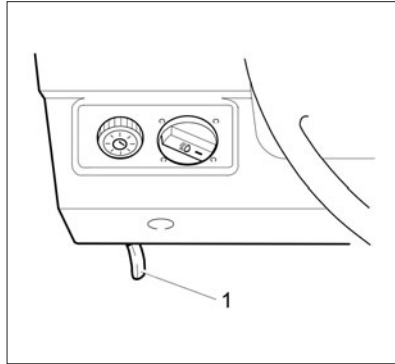

Fig. 6. Bonnet latch drive lever

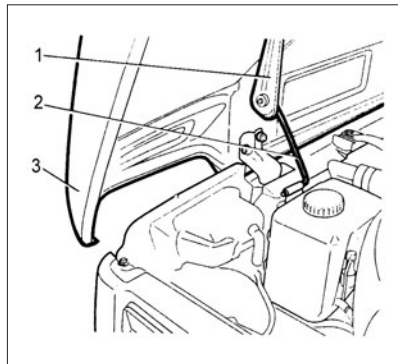

Fig. 7. Bonnet stay

PEDAL LOCATION AREA

Pedals

Nothing must interfere with operation of gas, brake and clutch pedals (see Fig. 13 items 28, 30, 32) and prevent their full travel.

You should use only such floor carpets that will not interfere with operation of pedals and can be securely fixed.

ATTENTION!

Do not put any items on the floor in front of and beneath the driver's seat because when braking an object might get into pedal arrangement area and hinder their normal operation. When it should come necessary to avoid a prang or perform a fast maneuver you will not be able to perform emergency hard braking, sudden clutch operation or opening up the engine.

Wearing appropriate foot-gear when driving a car

You should wear foot-ware that is to your right foot size and enables touch sensing the pedals.

SEATS

To adjust front seats in longitudinal direction pull locking lever 1 (Fig. 8) upwards. Once the seat has been moved to desired position release the lever. Seat reclining angle adjustment is continuously variable by rotation of knob 6. «A» diagram displays how front seats are unfolded to rest position. To install child seating module the passenger seat has to be set to last but one position.

ATTENTION!

Do not adjust driver's seat when driving the car. It may suddenly move sharply which will lead to losing control of the car.

To seat passengers on the back seat displace knob 2 and incline the backrest forwards. As this takes place, all seat is displaced forwards making space for the passengers to access the backseat.

Headrests of 3 front seats are height adjustable. Spring type hold-

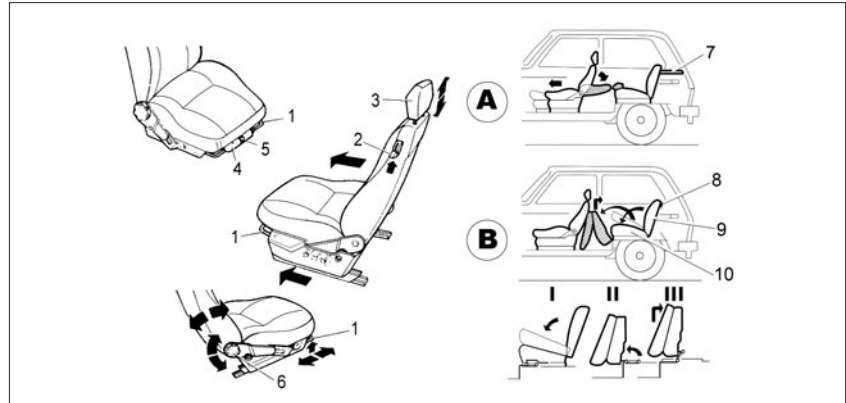

Fig. 8. Seats

ing locks retain then in desirable position.

A place under the driver's seat is provided to fasten fire-extinguisher 4 with elastic belt 5.

Back seat is designed foldable.

Diagram «B» shows how to increase trunk area space:

- remove shelf 7 and tilt backrests of front seat forwards;
- press handles 8 of back seat 9 locks and lay the backrest on seat cushion 10 (position I);
- bring the folded seat to position II;

- raise the seat a little and move it back to position III;
- after loading the luggage lay the shelf 7 in the luggage compartment and adjust backrest angles of front seats to position comfortable for riding.

MOUNTING OF CHILD RESTRAINT SYSTEM

WARNING!

Never hold a child on your knees in the moving car!

Standard safety belts for adult passengers are used in your car to fasten child retaining device.

Secure placement of children in the car is possible only when using certified children's retaining devices.

When mounting a child retaining device in your car you should be guided by the diagram attached to it.

For higher child safety it is desirable that the child retaining device should be mounted on the back seat.

WARNING!

1. It is prohibited to use a rearward facing child retaining device on the front right seat protected with passenger airbag mounted in front of this seat.

2. In cars equipped with front passenger airbag there is a warning label located at the side of instrument panel in order to remind you that you should never mount a child retaining device on the front seat with its back side facing forwards.

When choosing baby restraint system it is required to be guided by information given in table «Accordance of baby restraint mechanism to seats of their mounting in a car». Baby restraint mechanism can be installed in Your car only if meets requirements of European standard ECE R44.

Accordance of baby restraint mechanism to seats of their mounting in a car

Baby mass group	Type of child restraint mechanism	FR passenger seats	RR passenger seats	
			side	middle (for LADA 2131)
Category «0» < 10 kg (average 0–6 months)	Cross baby cradle	X	U	X
Category «0+» < 13 kg (average 6–18 months)	Baby seat, mountable against the direction of movement	X	U	X
Category «1» 9–18 kg (average 9 months – 3,5 years)	Baby seat, mountable against the direction of movement	U	U	X
	Baby seat, mountable in the direction of movement	U	U	X
Category «2» 15–25 kg (average 3,5 – 6 years)	Baby seat, mountable in the direction of movement	U	U	X
Category «3» 22–36 kg (average 6–12 y.o.)	Baby seat, mountable in the direction of movement	U	U	X

U – seat suitable for mounting of «universal» baby restraint mechanism mountable against direction of movement and officially approved for this mass group.

X – seat not suitable for mounting of baby restraint mechanism.

Mounting of baby restraint mechanism ISOFIX

Variant execution of Your car is equipped with fastener systems ISOFIX located on side seats of RR seat. Fastener systems ISOFIX allow to mount baby restraint mechanism ISOFIX corresponding to European standard (ECE R44) requirements.

Fastener system ISOFIX consists of two low brackets ISOFIX and bracket for upper safety belt ISOFIX.

Low brackets ISOFIX (to which the corresponding fixators of baby restraint mechanism are connected ISOFIX) located at the base of RR seat back and indicated with round pictograms with inscription «ISOFIX». Before connection of baby restraint mechanism fixators ISOFIX it is required to clear a space of low brackets location ISOFIX placing locks of RR safety belts along the line of joint of cushion and RR seat back.

Bracket to mount upper safety belt ISOFIX is located on the body floor behind RR seat back. Upper safety belt holder ISOFIX is made by straight part of wire staple of low inner holder ISOFIX. After fixation of upper safety

belt ISOFIX adjust its tension according to Manufacturer Instruction of baby restraint mechanism ISOFIX.

When choosing of baby restraint mechanism ISOFIX it is required to be

guided by information given in table «Accordance of baby restraint mechanism ISOFIX to seats of their mounting in a car». Baby restraint mechanism ISOFIX can be mounted in Your car only

Accordance of baby restraint mechanism ISOFIX to seats of their mounting in a car

Category on mass	Dimensional class of baby restraint mechanism ISOFIX	Position of ISOFIX holder in a car	
		RR RH side	RR LH side seat
«0» (from 10 kg)	F (Cross cradle ISOFIX)	X	X
	G (Cross baby cradle ISOFIX)	X	X
	E (Baby seat ISOFIX mountable against direction of movement)	IL	X
«0+» (till 13 kg)	E (Baby seat ISOFIX mountable against direction of movement)	IL	X
	D (Baby seat ISOFIX mountable against direction of movement)	X	X
	C (Baby seat ISOFIX mountable against direction of movement)	X	X
«I» (9-18 kg)	D (Baby seat ISOFIX mountable against direction of movement)	X	X
	C (Baby seat ISOFIX mountable against direction of movement)	X	X
	B (Baby seat ISOFIX mountable along direction of movement)	IUF	IUF
	B1 (Baby seat ISOFIX mountable along direction of movement)	IUF	IUF
	A (Baby seat ISOFIX mountable along direction of movement)	IUF	IUF

IUF – seat suitable to mount on direction of movement, «universal» of this category of baby restraint mechanism ISOFIX.

IL – seat suitable to mount «half-universal» of this category of baby restraint mechanism ISOFIX.

X – seat is not suitable to mount this category of baby restraint mechanism ISOFIX.

it corresponds to European standard (ECE R44) requirements.

WARNING!

Make sure that holders of baby restraint mechanism ISOFIX during its mounting in a car not to damage safety belts of RR seat.

Operation of baby restraint mechanism ISOFIX must be done according to Manufacturer's Instruction of baby restraint mechanism ISOFIX.

SEAT BELTS

To don the seat belts, insert the catch 1 (Fig. 9) into the lock 2 until it clicks, when doing this do not allow the straps twisting. To unbuckle the seat belt press button 3 of the lock.

Rear side passengers don the seat belts in the same way. A special design seat belt is provided for the middle passenger (VAZ-2131) – with two catches and two locks, it being known that in order to bring the belt to initial position the end catch should be inserted to the lock with a black button.



Fig. 9. Safety belts

ATTENTION!

Do not don the seat belt on a child seating on the passenger's knees.

When the straps get dirty clean them with weak soap solution. It is inadmissible to press the straps with an iron. The seat belt is subject to mandatory replacement with a new one if it has been exposed to critical load in a road traffic accident or has ruptures, abrasions and other damages.

SUN VISORS AND MIRRORS

Position I of the sun visors 1 (Fig. 10) can be changed to position II or III depending on direction of sun rays.

Interior rear-view mirror 2 has two fixed positions of A and B. To prevent dazzling with light of headlamps of a vehicle moving behind the car change mirror tilt angle with little lever 3.

Outside rear view mirrors are adjusted manually in all directions.

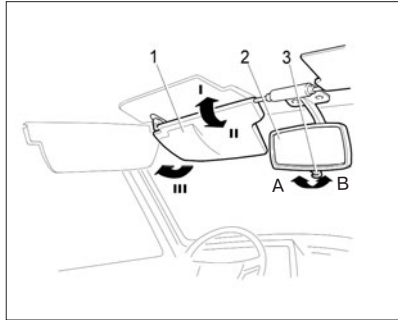

Fig. 10. Sun visors and mirrors

HYDRAULIC POWER STEERING

Optionally, the car is equipped with hydraulic power steering which considerably decreases steering wheel force. If hydraulic power steering is not in operation (for example, when towing the car with the engine stalled) drivability of the car is maintained although this would require much higher efforts applied to the steering wheel.

ATTENTION!

Do not allow movement with engine stalled and set to neutral gear! In this case hydraulic power steering and vacuum brake booster do not operate, so you endanger yourself and other traffic participants.

VAZ-2131 CAR MODEL AND ITS MODIFICATIONS

Long-wheelbase (extended) VAZ-2131 car model with five-door station wagon body and also its modifications differs from base specification VAZ-21214 model with extended (by 500 mm) wheelbase and equipment.

Tailgates

Tailgates (Fig. 11) have a latch which can be locked by pressing latch locking button 1 both with open and shut door. As this takes place, the outside handle and inside lever 3 will have idle stroke.

Drop window of the door is lowered and raised by rotation of window regulator handle 2.

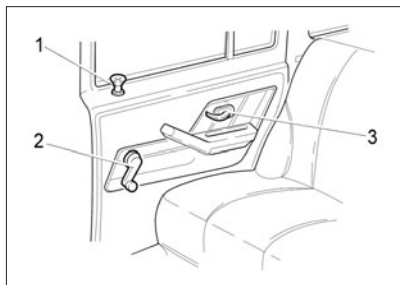

Fig. 11. Tailgate

Trunk compartment door

Trunk compartment door latch drive handle is located at LH front seat on a special bracket.

Back seats

The car is fitted with original back seats. Laying of back seats with the aim to increase trunk compartment space is shown on Fig. 12 and is done in the following sequence:

- remove the shelf 1 and lay it along the rear wall of trunk compartment;
- pull by hinge 3 and put the seat cushion in vertical position. The

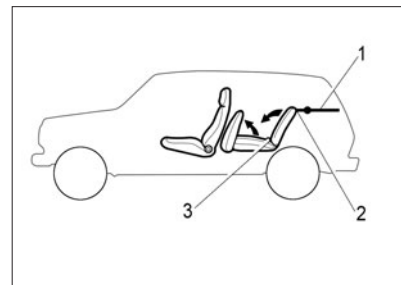

Fig. 12. Laying of a back seat

hinge is in the middle part of the cushion;

- having moved handle 2 right, release the backrest and lay it. If needed, move the front seats forwards.

Front seats

The front seats are adjusted on a stationary vehicle with the front doors open.

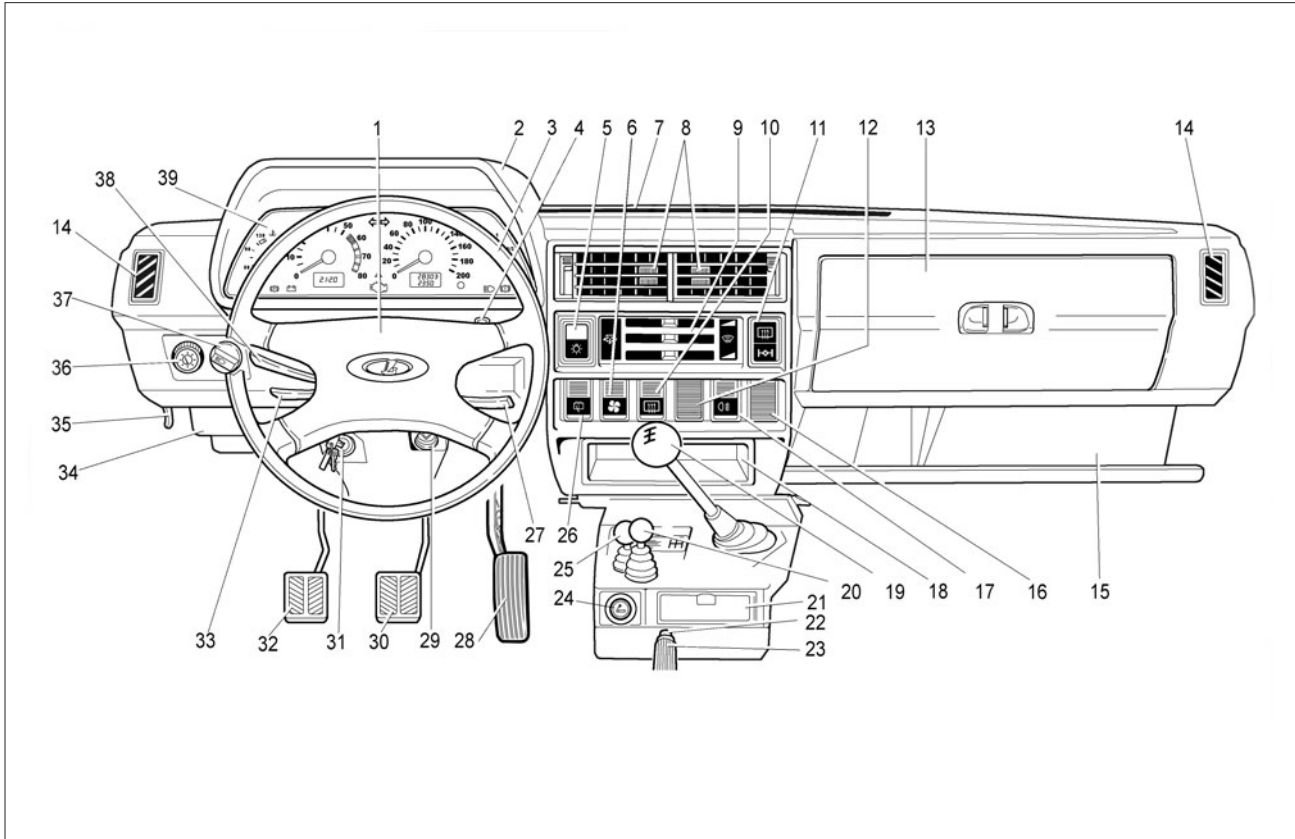

Fig. 13. Car controls and instrumentation

CAR CONTROLS

Arrangement of car controls is shown in Fig. 13.

- 1 – horn switch.**
- 2 – instrument cluster dashboard.**
- 3 – steering wheel.**
- 4 – dashboard fixation screw.**
- 5 – outer lighting switch.**

When pressing the key arm down to the first fixed position, marker light turns on; when pressing it down to the second fixed position, headlamps are turned on additionally, with a bulb in the switch highlighting the key.

- 6 – heater electric motor fan switch.**

When pressing the key arm down to the first fixed position, low fan speed is turned on, when pressing it down to the second fixed position, high speed is turned on. When turning on exterior lighting, key symbol highlight bulb turns on.

- 7 – windshield air blow-off nozzles.**

- 8 – central nozzles of interior ventilation and heating system.**

- 9 – interior ventilation and heating system ECU.**

- 10 – rear glass heating switch.**

Rear glass heating switch is switched on by pressing the key arm. When turning on exterior lighting, key symbol highlight bulb turns on.

- 11 – rear glass heating indicator bulb block of heating  and differential interlock .**

- 12 – plug.**

- 13 – glove box.**

- 14 – front doors glass defogging nozzles.**

- 15 – shelf for first-aid box, magazines and newspapers.**

- 16 – plug.**

- 17 – rear fog light switch.**

The fog lights are turned on when headlamps are on in conditions of restricted view (fog, snow, heavy rain) by pressing the key arm.

When external lighting is switched on key symbol highlight bulb turns on.

- 18 – cavity/socket for mounting of radio/multimedia.**

Installation of radio/multimedia shall be carried out only in a validated enterprise of sales and service network with mandatory mark in the service book.

ATTENTION!

Voluntary installation of current consuming devices might lead to wiring overload and fire.

- 19 – gearshift lever.**

20 – gearshift lever in transfer case.

- 21 – ashtray.**

22 – parking brake lever holding button.

- 23 – parking brake lever.**

By moving the lever upwards brake pads of rear wheels are actuated. To return the lever to initial position press the button 22 and lower the lever.

ATTENTION!

If in exceptional case you would have to use the parking brake when the car is moving, do not draw it too tight and keep holding the button on the lever pressed. Otherwise, interlocking of rear wheels may occur leading to skidding.

24 – cigarette lighter.

To use it press the socket button down to its fixed position. In about 15 s the socket will automatically return to initial position and becomes ready for using. When instrument illumination is on the cigarette lighter socket is highlighted with a bright-up lamp.

25 – differential lock lever in transfer case.**26 – rear screen wiper and washer switch.**

When pressing the key arm down to the first fixed position the wiper is turned on; further pressing to the second non-fixed position additionally turns on the washer.

27 – windscreen and headlamp wiper and washer switch lever.**28 – accelerator pedal.****29 – hazard light switch.**

When pressing the button blinking light of turn indicators comes on and also a bulb in the button itself. Hazard light is turned off when the button is pressed again.

30 – brake pedal.**31 – ignition switch.****32 – clutch pedal.****33 – turn indicator switch lever.****34 – fuse boxes.****35 – bonnet latch operating lever.****36 – instrument illumination control.**

By turning the knob instrument illumination brightness is adjusted and also highlighting of symbols if outside lighting is on.

37 – beam adjuster.

By turning the knob, depending on the load applied on the car, headlamp light beam angle is adjusted in such a way that to avoid dazzling of on-coming vehicle drivers.

Knob positions, when reviewed in the order of increasing of circles diameters on the beam adjuster scale mean as follows:

- driver alone or plus passenger on the front seat;
- all the seats are occupied or driver alone plus 100 kg cargo in the luggage compartment for VAZ-21214 and 200 kg for VAZ-2131 car;
- all the seats are occupied plus cargo in the luggage compartment of up to permitted maximum vehicle weight (PMM) or driver alone plus 250 kg cargo in the luggage compartment with unfolded back seat for VAZ-21214 and 350 kg for VAZ-2131 car.

For other options of car loading without exceeding of car payload and intermediate position of the knob should be selected.

38 – headlamp switch lever.**39 – instrument cluster.**

INSTRUMENT CLUSTER

Instrument cluster is shown in Fig. 14, where:

1 – coolant temperature indicator.

The indicator hand entering the red area of the scale denotes engine overheating.

ATTENTION!

Car operation with the engine overheated, when the indicator hand is in the red area, is prohibited. The car must be delivered to a validated enterprise of sales and service network to identify and eliminate the cause of engine overheating.

2 – tachometer indicates engine crankshaft rpm. The area of the scale with red shading denotes engine operation condition with a high crankshaft speed, the red area of the scale means dangerous engine operating conditions.

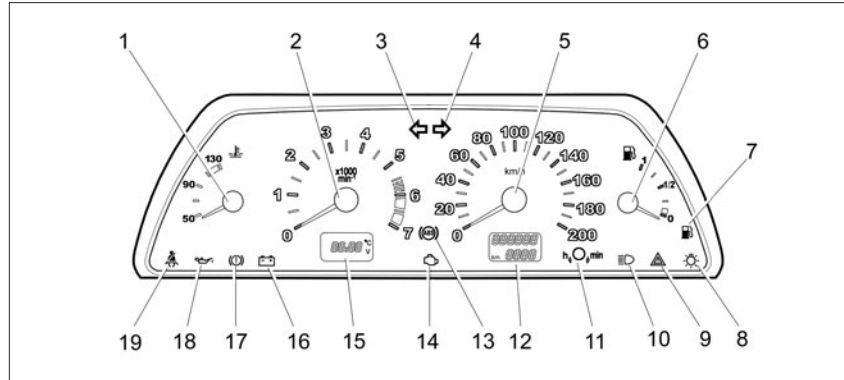

Fig. 14. Instrument cluster

ATTENTION!

Do not allow engine operation condition with indicator hand pointing at the red area of the scale nor with engine speed of less than 800 min⁻¹ at starting and in movement.

3 – LH direction indicator control lamp.

Lights up with green blinking light when switching left-hand turn.

4 – RH direction indicator control lamp. Lights up with green blinking light when switching right-hand turn.

5 – speedometer.

6 – fuel indicator.

7 – fuel reserve check indicator. Lights up with orange light if the fuel tank contains less than 4–6.5 L.

ATTENTION!

Never allow complete running out of fuel. This intensifies wear of fuel system units and may lead to an emergency situation on the road caused by sudden interruption of your car movement and also catalytic converter overheating and damage.

8 – marker light switch indicator lamp.

Lights up with green light when turning on outside lighting.

9 – indicating lamp of faulty Electronic distribution of brake forces (in optional design version).

Lights up with red light when turning on ignition and goes out after engine start-up (self-testing mode).

ATTENTION!

Car operation with continuously lit indicating lamp is prohibited. As this takes place, you should apply to a validated enterprise of sales and service network.

10 – headlamp high beam switch indicator lamp.

Lights up with blue light when switching the upper beam.

11 – reading reset button.

12 – mileage indicator.

The top line of the indicator displays total miles while the bottom line is a daily trip-meter. To reset daily counter reading press and hold down the reset button 11 for more than 5 s with the car stopped. Setting the daily counter to zero also occurs when removing the battery terminal.

13 – ABS indicator lamp (in optional design version). Lights up with yellow light when turning ignition off and goes out after engine start-up (self-testing mode).

ATTENTION!

In all other cases indicator lamp lighting gives evidence of a fault occurrence, which must be eliminated only in a validated enterprise of sales and service network.

14 – Check lamp «check engine».

The lamp lights up when turning on ignition and goes out after engine start-up if engine ECU (EMS) is clear from faults.

In case of detecting of any defect in the system the lamp is on continuously or blinking.

15 – indicator of time, temperature and car-system voltage.

Switching over between indication of time, ambient air temperature and on-board car-system voltage is done by short-time pressing of button 11.

When turning on ignition at ambient air temperature of higher than +2 °C time indication is always displayed. When ambient temperature

drops below +2 °C the indicator displays time (hours) readings for 3 seconds and then switches over to temperature display, the reading being blinking for the first 10 seconds.

When outside air temperature exceeds +3 °C and then again goes below + 2 °C:

– being in hours display state the indicator automatically switches over to temperature display, with the reading blinking for the first 10 seconds;

– in case of temperature indication, its normal mode of operation is interrupted with 10 second long blinking.

Setting of hours and minutes is done in time indication mode by turning of button 11 towards characters «h» (hours) and «m» (minutes).

After removal of terminal contact from accumulator battery and subsequent voltage recover the time count starts from zero.

16 – accumulator battery charge indicator lamp. It is lit red when turning on ignition and goes out after engine start. Bright lighting of the bulb of its half-glow lighting when the engine is running is indica-

tive of slack tension (break) of alternator drive belt or charge circuit failure or possibly alternator itself.

17 – check lamp of braking system emergency state and parking brake turn on. It is lit red when fluid level in brake hydraulic drive tank drops below «MIN» mark when engaging parking brake.

ATTENTION!

Lighting of indicator lamp when parking brake is off is indicative of brake fluid low level. Car movement is prohibited until elimination of fluid low level cause.

18 – low oil pressure indicator lamp. It is lit red when turning on ignition and goes out after engine start. Red lit when engine is running if oiling system pressure is low.

ATTENTION!

In case of indication of emergency oil pressure level value you should immediately stop moving, stall the engine and apply to LADA dealer for elimination of the failure, because low level in lubrication system leads to heavy damage of the engine.

19 – driver and front passenger unfastened seat belt indicator lamp. It is lit red at ignition turn-on if the driver's seat belt is not donned.

Simultaneously with light signaling turn on buzzer beep is sounding.

WARNING!

When driving always don the seatbelt and never carry passengers unfastened with seat belts!

UNDER-STEERING-WHEEL SWITCHES

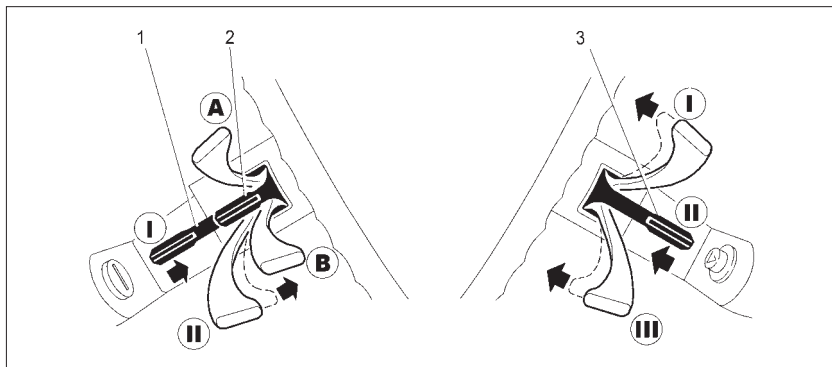

Fig. 15. Under-steering switches

If ignition is on, the headlamps energized with external lighting switch, and **lever 1 (Fig. 15) of dimmer switch** takes the following positions:

I – dimlight on; **II** – high beam on. Headlamp high beam can also be switched on by inward movement of the lever along the steering column (nonlocking position), irrespective of exterior lighting switch position and position of the key in the ignition switch.

When moving **lever 2 of turn indicator switch to «A»** position right turn indicators are switched on,

to **«B»** position – left turn indicators are switched on.

Once the car has come out of the road turn back to the straight road the lever automatically returns to initial position. This operation can be performed manually.

Lever 3 of wind-screen and headlamp wiper and washer switch takes the following positions:

I – windscreen wiper on;

II – windscreen wiper intermittent operation is on;

III – windscreen wiper continuous operation is on.

By inward (pulling) movement of the lever (nonlocking position) wind-screen wiper is switched on, and if headlamp lighting is on then simultaneously headlamp wipers and washers are switched on.

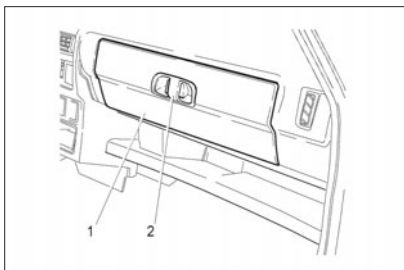

Fig. 16. Glove box

GLOVE BOX

To open glove box cover 1 (Fig. 16), press latch handles to knob 2 and pull.

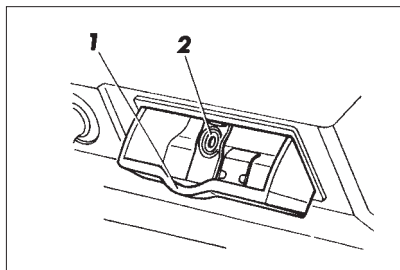

Fig. 17. Ash tray

ASH TRAY

To use it pull the projection 1 (Fig. 17). To clean the ash tray, press plate 2 of cigarette snub-out and remove it from the socket.

CAR OPERATION

LICENCE PLATE MOUNTING

The car is completed with a kit of fasteners to mount the licence plates.

Front licence plate is mounted on the front bumper with screws 1 (Fig. 18) and nuts 3 with washers 2.

To mount the rear licence plate insert plastic bushings 4 in the tail-gate and fasten the plate with self-tapping screws 6 with washers 5.

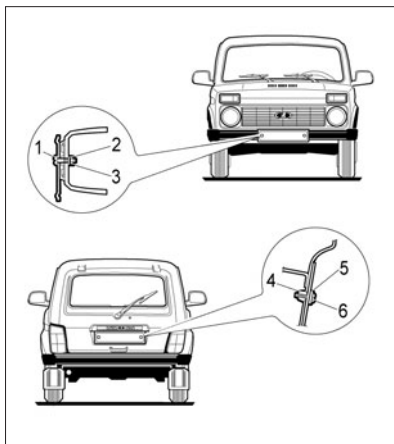

Fig. 18. Mounting of licence plates

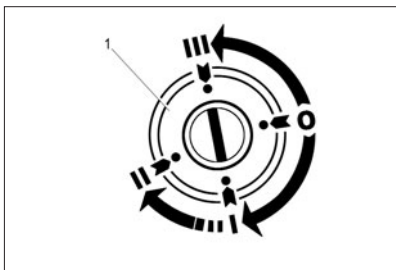

Fig. 19. Ignition switch

IGNITION SWITCH

Positions of key in ignition switch are shown in Fig. 19.

0 – ignition off. All is switched off, the key cannot be removed, and mechanical antitheft device is off.

I – ignition. Ignition is on, the key cannot be removed.

II – starter motor. The motor has been started, the key cannot be removed, key position unfixed.

III – parking. Ignition is off, with the key removed, mechanical antitheft device actuates and locks steering gear shaft.

To turn the antitheft device off insert the key into ignition switch and put it to zero position by slightly turning the steering wheel tight and left.

ENGINE START

Start features of engine with electronic control system

1. Press clutch pedal and set gear shift lever neutral position.
2. Insert the car key and turn on the starter motor. If the engine will not start operating at the first try switch ignition off and turn the starter motor on again in 20–30 seconds. Keeping the starter motor turned on for more than 10–15 seconds is not recommended. It is prohibited to press accelerator pedal during engine start. In case of heavy engine start (too much fuel delivered into combustion chambers) press the accelerator pedal as far as it will go and switch on starter motor for 10–15 seconds to purge cylinders and then release the accelerator pedal and start the engine in the prescribed manner.

In attempting to start the engine for longer than 20 seconds the starter motor will be switched off automatically (overtemperature protection).

Once the engine is started, release the ignition key and it will automatically come back to position I (refer to Fig. 19). In case of stable engine operation smoothly release the clutch pedal.

At ambient air temperature minus 25 °C and lower and also during heavy snowfalls it is recommended to put a radiator cover on trim grille holes for intense engine warm-up and to maintain its thermal conditions.

Engine start in cold season

The present recommendations ensure starting of a properly operating vehicle with accumulator battery charged at least up to 75%.

1. Crankcase oil must comply with ambient temperature (refer to Appendix 1).
2. Gasoline volatility class – for winter period depending on climatic region is used as per GOST R 51105-97.

3. Minimum electrode gap of ignition plugs, i.e. to 1 mm, is recommended in winter period.

4. When leaving a car for long time at parking place in the open air it is recommended to «burn» ignition plugs before engine cutoff. To this end, increase engine rpm up to 3000 min⁻¹ and then stall it.

5. Before starting, take a pause of a few seconds with ignition on for electric fuel pump to have time enough to increase pressure in the fuel rail up to working value.

6. Hold clutch pedal pressed before and during engine starting and do not apply accelerator pedal.

7. If during 10 seconds there is still no sparking in the cylinders, stop your attempt to start the engine. Repeat the attempt in 40 seconds.

8. If the second attempt to start the engine was a failure, the third attempt should be started with accelerator pedal pressed all the way down (cylinders drainage condition). After 6–8 seconds of purging start smoothly releasing accelerator pedal and hold it in a position when sparking will occur.

9. If even the third try to start the engine is a failure, it means that either ambient temperature is lower than prescribed by Technical Specifications (minus 25 °C is margin of engine cold start capacity without auxiliary devices) or the engine has been out of order, or there exist some deviance from recommendations set forth above.

An engine equipped with electronic fuel injection (EFI), catalytic converter and oxygen sensor operates properly only if unleaded gasoline is used. Leaded gasoline will disable these elements in a short time and this leads to smoky exhaust emission, sharp increase of fuel consumption and degradation of car dynamic performance.

ATTENTION!

Catalytic converter is a costly unit designed to provide environment protection. The catalyst may break down, and in case of misfire (piston knock and jerks of the car when moving) fuel will be ignited in the catalyst, with its temperature sharply increasing. Engine ECUs have catalyst mis-

fire protection function. CHECK ENGINE indicator starts blinking when cut-outs occur in one or two cylinders, delivery of fuel is cut off to cylinders in which misfire has been detected; after that the indicator is glowing continuously. In occurrence of misfire immediate actions must be taken for its elimination.

For vehicles equipped with catalyts cranking by towing is only allowed with cold engine. It is preferable to start the engine with another car's battery using auxiliary cables. By no means use starter motor to move the car.

ELECTRONIC ANTITHEFT SYSTEM

Part of the cars produced are equipped with electronic antitheft system ensures that the engine can only be started after reading a code from a key. The cars are fitted with АПС-4 antitheft system. Immobilizer – an electronic control module – is the main element of the electronic antitheft system. After reading a code from the working code key and identifying its code value the immobilizer generates enabling code command to engine ECU. The immobilizer has an integrated protection function against key fitting and code reading. The code key includes a special unit enabling translation of a code value in a coded and continuously varying state. Code keys have an inscription denoting an antitheft system type.

АПС-4 antitheft system user manual

Cars fitted with АПС-4 electronic antitheft system are provided with additional protection against unauthorized use by means of engine start disabling.

The antitheft system set includes code keys additionally attached to the car. The two black keys are working code keys which should be normally used for releasing of guard mode and one red key used as a teaching (programming) code key. The teaching code key is used for antitheft system activation and initial teaching of working code keys and also to reprogram the system when a working code key is lost and to teach additional working code keys as well as to restore working condition of the system when replacing faulty electronic units.

АПС-4 antitheft system allows to teach and operate simultaneously 1-4 working code keys.

The antitheft system must be activated during PDI (predelivery inspection). Make sure that the antitheft system has been connected

and operates properly. To this effect, shut all the doors of the car except for the driver's door. Step into the car and shut the driver's door. System status LED indicator must start blinking at a frequency of two times a second. Approach anyone of the black code keys to the indicator, the LED must go out at this and at the same time a double beep signal must sound. After that you may turn on ignition and start the engine – the antitheft system operates properly.

ATTENTION!

If the engine can be started without putting the key to indicator it means that the antitheft system is inactive, and you should request for its programming and bringing to active state when buying the car and after its technical maintenance.

Antitheft system entry into guard mode is occurring automatically upon ignition turnoff and depends on further actions of the driver. If the driver's door has not been opened or has been opened and remained opened, then setting to guard mode

occurs in 5 minutes; if the driver's door has been opened and then closed, then setting to guard mode happens in 30 seconds from the moment of door closing.

In all cases, a beeping sound is heard with increasing pace 15 seconds before setting the system to guard mode and indicator LED glints.

If setting to guard mode is not desirable it can be disabled by turning the ignition key to «ignition turn-on» position.

Guard mode release

To release the antitheft system from guard mode switch it over to key code «reading» mode in which LED indicator is blinking at a frequency of 2 times a second. Entry into «reading» mode is possible in two ways:

- by opening or closing of the driver's door; in this case «reading» mode lasts 1.5 minutes;

- by turning of ignition on and off in which case «reading» mode lasts 10 seconds.

Put the system to «reading» mode and approach any one of the black code keys to indicator – LED indica-

tor must go out simultaneously with double beep sound. After that you can switch ignition on and start the engine.

ATTENTION!

Never use the red key to release the antitheft system from guard mode, this might disable engine start. In view of importance of the red key please keep it secure at home. In case of loss of the red key, once the antitheft system has been activated, warranty obligations on the system and engine ICU quality are not assumed.

Particular cases

1. Loss of a working code key and teaching additional working code keys.

In case of loss of working code key it is recommended that the system be reprogrammed using the remaining code keys in order to prevent its unauthorized use and auto theft. Then it is possible to by new working code keys and teach the system anew with the use of remaining and new code keys. Reprogramming is performed by LADA dealer.

2. Loss of a teaching code key.

In case of loss of a teaching (programming) key it is not possible to perform reprogramming of new code keys as well as the remaining working code keys. This means that car operation is possible with the available working keys but in the event of their loss or immobilizer fault it will be necessary to replace immobilizer, engine control unit and also all code keys for new unprogrammed ones. Following such replacement, it will be necessary to go through procedure of antitheft system activation by LADA dealer.

3. Faulty immobilizer replacement.

Antitheft system teaching procedure must be performed by LADA dealer after replacement of a faulty immobilizer.

4. Replacement of faulty engine control unit (ECU).

A faulty ECU needs to be replaced for a properly operating one with its antitheft function nonactivated. After such replacement it will be necessary to have the antitheft system activated by LADA dealer.

5. Antitheft system diagnostics.

If after releasing of the antitheft system guard mode and ignition turn-on the LED indicator blinks 1-2 times and goes out it means that antitheft system is in good order. If after releasing of the antitheft system guard mode and ignition turn-on system status LED indicator blinks 1 time per second and engine will not start it means that the antitheft system is faulty. It is necessary to apply to LADA dealer for fault elimination.

Courtesy light turn-off delay control

This function allows keeping passenger compartment illuminated for a while after car door closing which facilitates driver's when it is dark.

To enable this function, the light switch must be set to «Off» position. In this state, the light is turned on with door opening and glows all the time while the door is open. If ignition has not been switched on, then after closing the door the lamp keeps glowing for 12 seconds more and then smoothly goes out within 4 se-

conds. If the door is closed with ignition turned on, the light goes out right after door closing. If during courtesy light turn-off delay operation the ignition key is set to «On» state, then courtesy light will go out without delay.

If during courtesy light turn-off delay operation the door is repeatedly opened, the light is turned on and keeps lighting all the time while the door is open and further on – as described above.

Alternative engine start procedure

This procedure enables engine starting for one trip without code reading from working (black) key in case of its loss or faulty antitheft system. The procedure is possible to use only in case of preprogrammed «bypassing password» consisting of six digits. Activation of alternative engine start procedure must be performed during PDI of maintenance of the car by LADA dealer only at the owner's will and in his presence.

How to use immobilizer and ignition keys

To start engine on the car equipped with electronic antitheft system:

1. After opening of any of the doors or short-time ignition switch-on (if door switch is out of order) immobilizer switches over to «code reading readiness» mode for 30 seconds – light indicator 1 (Fig. 20) of signaling sensor 2 is blinking with double frequency.

2. During this time interval approach working code key 3 to indicator sensor. After code reading immobilizer unit identifies its validity – light indicator glows for 2 seconds and goes out and enables electronic engine control unit thereby enabling engine starting.

Perform engine start by turning the key in the ignition switch 1 (See. Fig. 19) from position I («ignition») to position II («starter motor»).

Ignition switch has locking which prevents starter motor switch-on while the engine is running. For repeated engine start after abortive attempt set the key from position I to

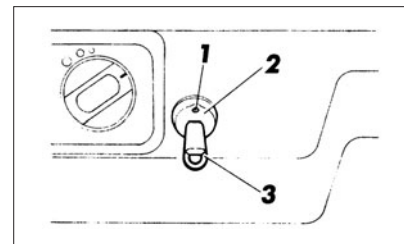

Fig. 20. Instrument panel (fragment)

0 («Off») and then turn the starter motor on again.

The key is removed when in position III of ignition switch. As this takes place, mechanical antitheft device is actuated which locks the steering shaft.

In order to avoid auto theft do not leave the key in the ignition switch!

ARRANGEMENT OF TRANSFER CASE LEVERS

Differential locking lever can take the following positions (Fig. 21):

- P – unlocked;**
- Б – locked.**

When switching on locking differential locking indicator lamp 11 lights up (See Fig. 13).

Gear shift lever positions in transfer case mean as follows:

- H – low gear;**
- N – mid-gear;**
- Б – top gear.**

After gearing up differential locking may be performed while in car movement with clutch released.

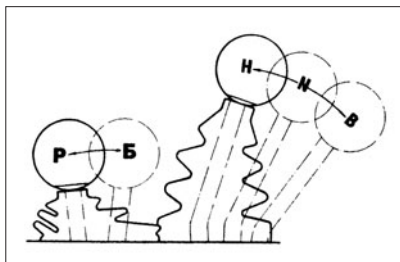

Fig. 21. Transfer box levers

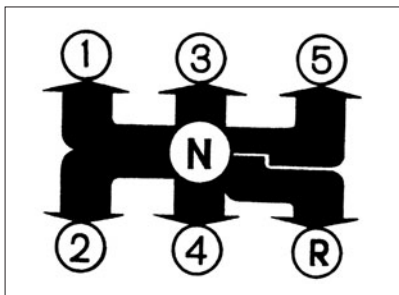

Fig. 22. Shift pattern

CAR MOVEMENT

Check positions of transfer case levers before driving – it should correspond to road conditions.

Start driving in first gear and with engine rotational frequency increasing perform upshift in appropriate time. Gear shift pattern is shown in Fig. 22.

The clutch used in this car has no gaps in the drive. In view of this, to avoid clutch slippage, release the pedal after gear shifting and clutch engagement. Do not keep your foot pressing clutch pedal when moving.

Shift down well-timed and according to current road conditions, switch over to low gear in the gear-box avoiding engine overload.

For backing, push gearshift lever as far as will go and move it to position corresponding to reverse gear

switching. Put in reverse gear only after car complete stop.

When hill climbing, taking off, towing a heavy trailer, moving on loose ground and also to obtain minimal driving speed on roads with hard pavement preliminary engage low gear in the transfer case. Engaging of transfer case low gear is recommended after car complete stop.

When passing rough road sections lock the differential in advance.

Do not lock differential at wheel-spin moment. After passing of such road sections unlock the differential because driving on good motorways with differential locked reduces power train mechanical life, increases tire wear and fuel consumption and might cause skidding when braking.

As far as possible, drive at moderate and constant speed. Brick acceleration and deceleration and driving at high speed leads to excess fuel flow. Moreover, fuel waste is also caused by low tire pressure, worn out or fouled spark plugs, using engine oil with higher viscosity than recommended.

During driving see after operation of the systems by watching instrumentation and indicator lamps. Red indicator lamps must not glow in normal conditions – their light is signaling that an appropriate system needs checking.

Passing fords and puddles

Driving through water barriers requires extreme attention as they might hide pits or underwater obstacles which can damage wheel discs or suspension parts. Passing water barriers with the depth of more than 0.5 m is inadmissible. Driving into water and wading must be performed carefully avoiding waves formed near radiator grille as this might cause water ingress through air filter intake to the engine. This will inevitably bring the engine out of operation.

Take special heed in the first minutes of raining as wetted dust on the road pavement forms slippery film sharply reducing tyre grip on the road.

Perform partial braking from time to time during driving to dry the brakes as efficiency of wet brakes is sharply reduced.

When overtaking, switch wind-screen wiper on and put it to maximum efficiency – this will help avoid visibility loss due to possible water splashing from under wheels of the vehicle being passed. Such safety precautions are also desirable when being overtaken.

Do not perform overtake in rainy weather if water drop cloud from under wheels of the car ahead completely closes overtake area visibility.

To avoid moving in the water tail of the cars ahead of you increase the distance and reduce driving speed.

When driving along sidewalks in rainy weather or after the rain and passing puddles slow down to avoid under wheel water splashing over pedestrians.

BRAKING AND PARKING

Brake system design ensures effective braking. However, try to perform smooth and moderate braking in all instances avoiding abrupt deceleration.

Do not turn ignition off and do not get the key out of the ignition switch when the car is moving. With engine stalled a higher force needs to be applied to the brake pedal to decelerate the car. Besides, when the key is out the steering shaft is locked with antitheft system and the car becomes unsteered.

In case of breakdown of one of the brake system circuits car deceleration is provided by the second brake circuit. As this takes place, brake pedal travel increases and braking efficiency is reduced which at first instant you may take for complete brake failure. In this case do not release the pedal and do not press the pedal repeatedly; this will only increase the length of the brake path; instead, press the pedal until you reach maximum possible braking effect.

When stopping on up-grade or on down grade engage parking brake and first or reversing gear respectively.

To prevent freeze-in of the brake pads to the drums after driving on wet roads with wide fluctuations in temperature do not leave the car on outdoor parking ground with parking brake engaged without having dried the brakes by regular smooth braking when driving to parking area.

ABS – Antilock Brake System

In option design versions the cars are fitted with antilock brake system (ABS) which prevent wheel locking at braking thereby ensuring that guided movement trajectory and minimum length of brake path are maintained in virtually any road conditions. However, braking on a road with loose pavement (gravel, sand, non-compacted snow) may cause some longer brake path as compared to braking in the same conditions with the wheels locked.

ABS also performs additional function of brake force distribution electronic control which at service

braking and failure of main ABS function ensures an optimum ration of front and rear wheel brake forces.

ATTENTION!

To avoid restriction of ABS performance do not fit the car with tyres of different size.

In emergency braking, apply the brake pedal as fast as possible with maximum force and hold it pressed up to the end of braking. Do not release the brake pedal even when car movement direction is changing at braking.

WARNING!

Cadence braking (brake pedal releasing an repeated pressing) increases the length of the brake path of cars with ABS.

ABS function at braking comes in starting with a speed of more than 8 km/h and is accompanied with slight pulsation of the brake pedal and characteristic noise of ABS actuator gears. ABS ceases operation when car speed drops to 3 km/h.

WARNING!

ABS indicator lighting evidences ABS function failure except for self-testing mode when turning on ignition. In this case operation of brake hydraulic drive is not impaired. Simultaneous glowing of ABS light indicator and brake force distribution electronic control indicator evidences failure of all ABS functions except for self-testing mode when turning on ignition. In this case early locking of rear wheels is possible at braking and dangerous skidding. In both cases the failure must be eliminated by LADA dealer as soon as possible.

Auxiliary braking system

Cars with ABS are equipped with vacuum brake booster and auxiliary braking system which identifies the need in emergency braking by rapid applying the brake pedal and automatically provides maximum braking efficiency throughout the time when the brake pedal is pressed.

CAR TOWING

When you need to tow your car fix the towrope only at specially designed front 1 (Fig. 23) or rear 2 tow eyes.

Before towing put the key in the ignition switch to «0» and turn off light signaling according to traffic regulations. When towing see to it that towrope is kept tense. Besides, note that the vacuum brake booster performs its function only when engine is running. Therefore, when braking apply much more force to the brake pedal.

Perform car towing smoothly without jerks and sharp turns.

OPERATION OF A NEW CAR

During making the first 2000 km of mileage:

1. Do not exceed speed values specified in Table 1.
2. Do not tow trailer and car without extreme necessity.
3. Such driving manners as abrupt takeoff including with parking brake engaged, turning with wheel spinning at maximum engine speed is **inadmissible** as this causes damage of differential.
4. Do not allow overheated engine running (threshold is 115 °C).
5. Before the end of brake pad run-in period (during 3000 km of mileage) relative difference in brake forces of rear axle wheels when measured to methods in line with GOST R 51709-2001 standard must not exceed 35%.

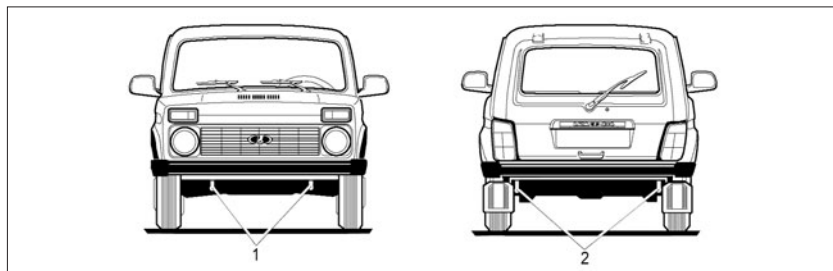

Fig. 23. Tow eyes

SAFETY PRECAUTIONS IN CAR OPERATION

The car is easily steered has high dynamic and speed performance on highway and also high cross-country capacity in conditions of wet dirt roads, sand and snow-covered terrain. However, bear in mind that the car is not designed for **permanent** operation in heavy road conditions.

Do not exceed loading of the car specified in the manual. Overload leads to damage of front suspension elements, bending of rear axle beam, early tire wear, vibration of body and loss of car stability. Weight of cargo with luggage container installed on the car roof must not exceed 50 kg without exceeding of payload.

Before you switch on the wipers in cold season make sure that the wiper brushes are not frozen to the glass. If this recommendation is ignored it may cause not only wiper damage but also breakdown of their drives.

Soft suspension of the car efficiently absorbs oscillations at fast driving on a road with irregular surface. However, sharp knocks may deform axes of lower arms and

Table 1
NEW CAR MAXIMUM SPEEDS, km/h

Mileage, km	Gear				
	first	second	third	fourth	fifth
0–500	20	40	60	80	90
500–2000	30	50	70	90	110

knock out of action other parts of chassis. Therefore, driving at high speed on such road is not recommended.

For lubrication of units and assemblies and charging of fuel tank use materials recommended by the manufacturer (See Appendix 1).

Do not allow car operation with when insufficient oil pressure indicator lamp is glowing.

Never allow engine running at engine speed when tachometer pointer is in red area of the scale. Tachometer pointer in red area indicates approaching engine speed to maximum permissible value. If maximum permissible crankshaft RPM value is exceeded then at reaching 6200 min⁻¹ ECU will start to cut off fuel delivery which may cause piston knock and jerks in care movement.

Fuel delivery is resumed when engine speed is reduced.

Operation of tires with air pressure values different from those recommended leads to their early wear and deterioration in car stability and response.

High-performance disc-type front brakes are applied in the car design. However, their durability is subject to proper maintenance – do not allow accumulation of consolidated mud in brake gears and wash after driving on deep mud road.

A high energy ignition system is installed in the car. Therefore it is prohibited to perform engine start by means of spark gap, disconnect high-tension wires on running engine and check high-tension circuits «for spark» as it might cause burnout of high-voltage parts and ignition system breakdown.

ECU-EQUIPPED CAR OPERATION FEATURES

Indicating lamp «  » turning on with the engine running does not imply that the engine must be stopped immediately – the ECU (electronic engine control unit) has backup modes enabling engine running in conditions close to normal. However the vehicle must be taken to LADA dealer at the earliest opportunity to detect the cause of indicating lamp illumination.

In ECU-equipped car with catalytic converter and oxygen sensor, the engine operates properly on condition that **unleaded** gasoline only is used. Leaded gasoline will soon knock these elements out of action which will be accompanied with smoky exhaust fumes and sharply increased fuel consumption.

ATTENTION!

Catalytic converter is a costly unit designed to provide environment protection. The catalyst may break down, and in case of misfire (piston knock and jerks of

the car when moving) fuel will be ignited in the catalyst, with its temperature sharply increasing which causes catalyst damage. Engine ECUs have catalyst misfire protection function. CHECK ENGINE indicator starts blinking when cut-outs occur in one or two cylinders, delivery of fuel is cut off to cylinders in which misfire has been detected; after that the indicator is glowing continuously. In occurrence of misfire immediate actions must be taken for its elimination.

For vehicles equipped with catalyts cranking by towing is only allowed with cold engine. It is preferable to start the engine with another car's battery using auxiliary cables or external 12 V current supply.

By no means us starter motor to move the car.

As the catalyst has high temperature, see to it that when parking the car there is no dry grass or other flammable material (rags, chips etc.) under the catalyst which is located in underbody area.

In the car equipped with EFI system ECU contains a function of switching on of electric fuel pump for 2 seconds when ignition is switched on.

Disconnection and removal of high-tension wires from ignition system devices must be performed only by pulling at the protective cap. **Wire removal by pulling at high-tension wire is prohibited!**

Engine start with a peripheral battery

When starting the engine with a peripheral battery the following should be considered:

1. Auxiliary battery voltage must be 12 V. Rated capacity difference of the discharged car battery and peripheral battery should not be significant.

2. Only cables with sufficient cross-section area (no less than 16 mm²) must be used when getting connected to an auxiliary battery.

Cable connection procedure is following:

First connect one cable end to positive pole of discharged battery «A» (Fig. 24), then the other end of the cable to positive pole of auxiliary battery «B». Then connect the end of the second cable to negative pole of external battery and the other one to car chassis ground as shown in Fig. 24.

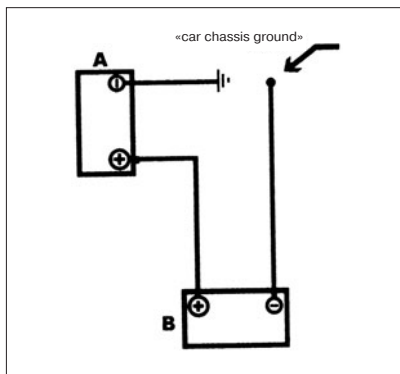

**Fig. 24. Auxiliary battery
connection diagram**

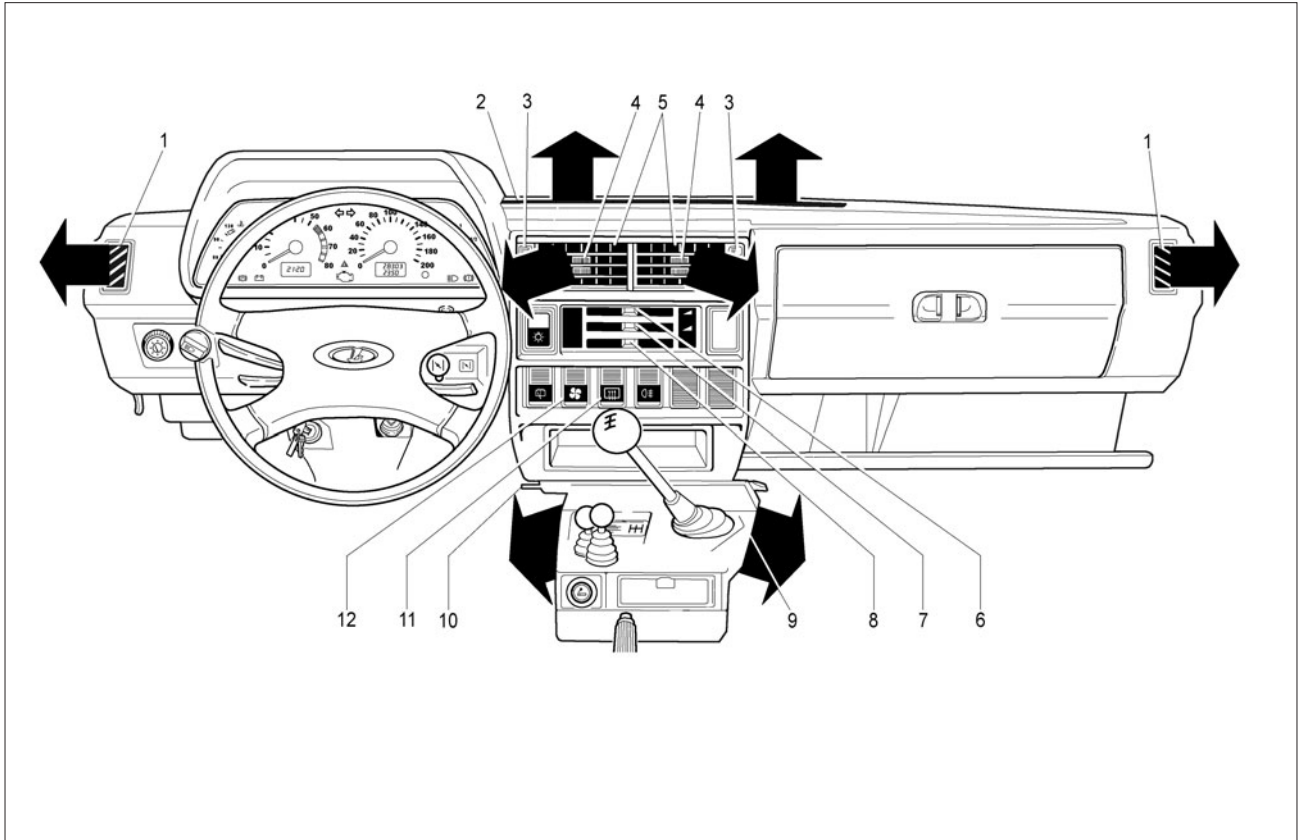

Fig. 25. Interior ventilation and heating controls

PASSENGER COMPARTMENT VENTILATION AND HEATING CONTROL

Interior ventilation and heating is regulated based on outer air temperature.

Interior ventilation

Outer air may come to car interior

- via open door windows;
- through nozzles 2 (Fig. 25) of windscreen blowing if distribution arm slide 8 and arm slide 7 of air intake flap control are moved right;
 - via door window blow side nozzles 1 if arm slide 7 is moved right and slide 8 moved left;
 - through holes 9 of heater housing to driver and front passenger feet area, if heater cover is opened with arm 10 and arm slide 7 is moved right;

– through central nozzles 5 directly from air intake box when the car is moving if nozzle flaps are opened with slides 3 (summer blowing). Air flow direction from the nozzle is changed by moving arm slide 4 horizontally and vertically. Arm slide 8 being middle position and slide 7 in extreme right position the air will come both through nozzles 1 and 2. When driving at low speed it is possible to increase amount of incoming air by turning on of heater fan with switch.

Windscreen, door windows and rear window demisting

To provide demisting of windscreen and door windows it is sufficient to direct air flow at them, for this

- close heater cover with arm 10;
- move arm slide 8 right and set arm slide 7 to middle position;
- turn heater fan on if necessary.

If incoming air needs heating slightly move arm slide 6 of heater valve control partially to the right.

For rear window demisting turn on its electric heater with switch 11.

Heating of passenger compartment

For heating of interior and defrosting and demisting of windscreen, door windows and rear window:

- move arm slides 6 and 8 right;
- set arm slide 7 to middle position;
- open heater cover with arm 10;
- turn on heater fan if necessary with arm 12;
- turn on rear window defrosting with switch 11.

Warm air will be directed both driver and passenger feet area and windscreen and front door window glasses. For fast defrosting of just windscreen close heater cover with arm 10 and move arm slide 7 right.

INTERIOR LIGHTING

Courtesy lights 1 (Fig. 26) are turned on automatically at door opening they are arranged in B-pillars. Interior lighting with the doors closed is turned on by pressing switch key 2.

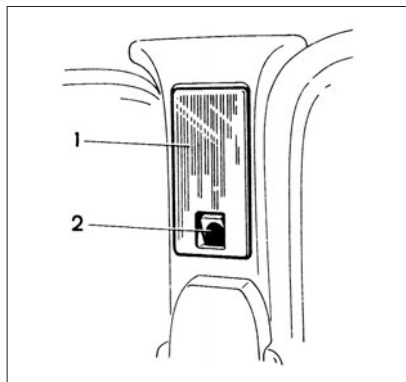

Fig. 26. Interior lighting

LADA 4x4 Urban VEHICLE VERSION

Vehicle description

LADA 4x4 Urban are equipped with specific units and systems to ensure the enhanced comfort for driver and passengers. The key information about the car is given in the LADA 4x4 operating manual. Study the operating manual and this addendum carefully prior to operation.

INTERIOR EQUIPMENT

Interior lamp

Interior lamp (Fig. 27) includes the section of individual lighting of driver's and front passenger's seats and the section of general lighting of interior. Left and right sections of the individual lightning are switched on/off by pressing the left **1** or the right **2** button respectively.

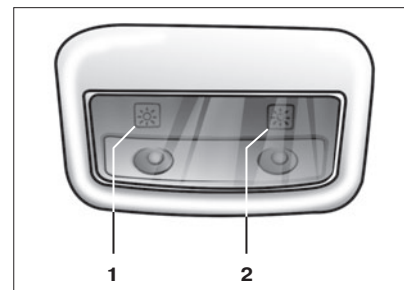

Fig. 27

Outer mirrors with electric drive

Outer mirrors are equipped with electric drive. Mirrors control unit (Fig. 28) is located on the floor cover trim (Fig. 29). Selection of the adjustable mirror is performed by shifting the switch **1** to the fixed positions (right/left), corresponding to the adjustment of right/left mirror.

Selection of the optimal position of mirrors is performed by inclination of the joystick disk **2** in four directions: up/down/right/left.

Outer rear-view mirrors are with electric heating activated simultaneously with the tailgate glass heating.

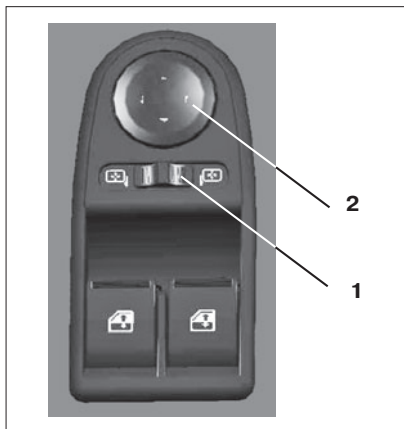

Fig. 28

ATTENTION!

Folding of outer mirror if not necessary is not recommended.

Glass holder

There is a space **1** for glasses or ashtray on the floor tunnel cover trim located in between front seats (Fig. 29).

WARNING!

When turning, accelerating or

braking take care to prevent the overflowing of liquid from container located in the glass holder.

If liquid is hot there is a danger of burning and/or overflowing of liquid.

Window lifters

Powered window lifters are used for lifting and lowering of doors windows. You can lower or lift RH/LH door window at the required level by lifting or lowering of the front arm of **2/3** switches located on the floor tunnel cover trim (Fig. 29). After the cessation of pressing the button is stopped automatically in the central position and the window stops at any selected position.

Windows get lowered not completely. It is due to the design of window lifters and is not a defect.

WARNING!

It is possible to pinch fingers and other parts of body while closing of windows with powered lifters that can lead to serious injury. That is why be careful when using the powered win-

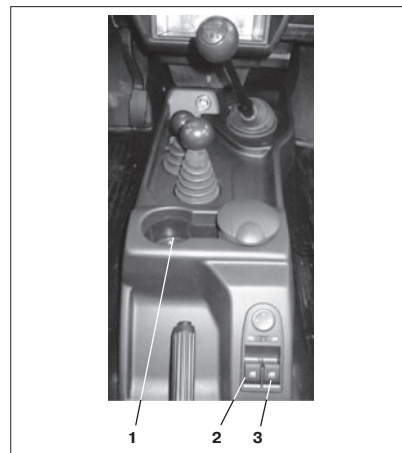

Fig. 29

dows, especially if there are children in the car. Make sure that the lifting window pinches nothing. In case of pinching stop lifting the window immediately and activate its lowering.

Car driver is fully responsible for the wrong usage of powered windows. He should notify the passengers about the usage rules and warn about dangers occurred in case of wrong usage of powered windows.

Don't let children to use powered windows switches!

When leaving the car it is obligatory to take the ignition key out from the switch to turn off the powered windows and prevent accidental injury of passengers left in the car. Don't put hands and other parts of body out of the open windows, prevent children from doing it.

WARNING!

In case of operating the car at low speed (eg. when moving slowly in the city, when driving at short distances or in the traffic jam) as well as at the engine idle run you should turn the power consumers off for example outer mirrors and rear window heating, if possible to reduce the discharge of the battery.



Fig. 30

Steering wheel with modified design

Horn

Vehicle is equipped with steering wheel with horn switches **1** (Fig. 30) which are located left side and right side from the steering wheel center.

Vehicle towing

(version LADA 4x4 Urban only)

Vehicle is completed by movable tow device **2**, which is mounted through special access holes **1** and **4** in front and rear bumpers (Fig. 31).

For mounting of towing eye, – take out the plug **1** from front bumper (**4** – from rear bumper), by inserting of screwdriver with flat blade into the groove under cover.

Screw the towing eye **2** until stop, first by hand and then – by combination wrench **3**.

After the towing, the detachable towing eye should be unscrewed and kept together with combination wrench **3**.

Fixing port is designed only for towing; never use it for lifting of vehicle, directly or indirectly.

ATTENTION!

For towing follow recommendations provided in basic Manual.

In all cases the recommended speed during towing is not higher than 25 km/h.

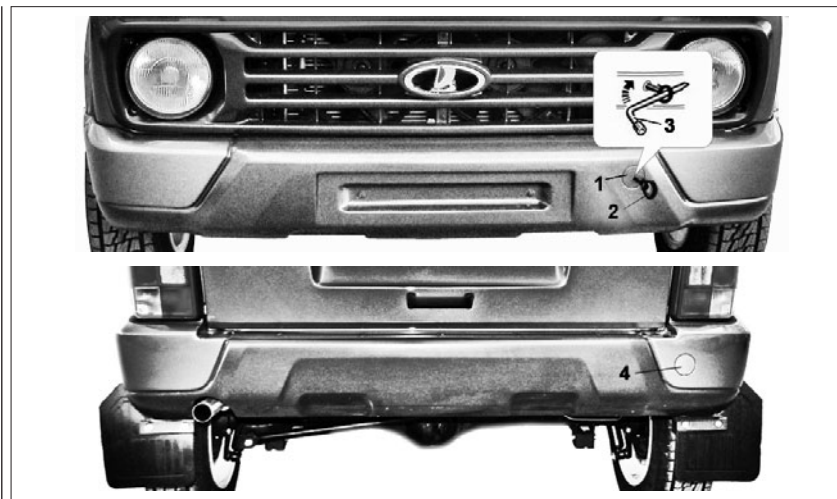

Fig. 31

Tyre dimension with bearing capacity index and speed index*	Wheel dimension		Air pressure in tyres, MPa (kgs/cm ²)	
	rim width	rim offset, (ET)**, mm	front wheels	rear wheels
Basic wheel with cast disc				
185/75 R16 92Q 95T	6Jx16H2	40 or 58	0,21 (2,1)	0,19 (1,9)
Temporary spare wheel				
185/75 R16 92Q 95T	5J	58	0,21 (2,1)	0,19 (1,9)

* Speed index: Q – under 160 km/h, T – under 190 km/h (except for temporary wheel with information plate on allowed maximum speed – 80 km/h).

Bearing capacity indices: 92 – 630 kg, 95 – 690 kg.

** Rim offset (ET) – space between mating face of disc to rim middle.

Spare wheel (version LADA 4x4 Urban only)



Рис. 32

Vehicle is completed by cast wheel disks and has a spare wheel with built-up steel disc.

In case when cast wheels and spare wheel have different rim offset, the stamped wheel can be used together with cast wheels only for a short time. In this case the maximum speed limit will be 80 km/h. Spare wheel disc has information plate **1**, for admitted maximum speed – 80 km/h (Fig. 32).

Size of rim offset (ET) is indicated on inner side of cast wheel rung.

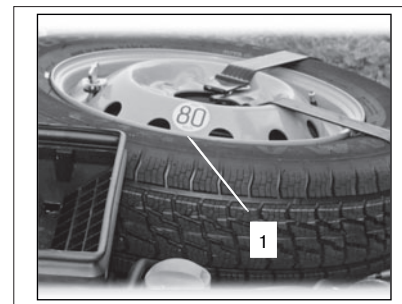
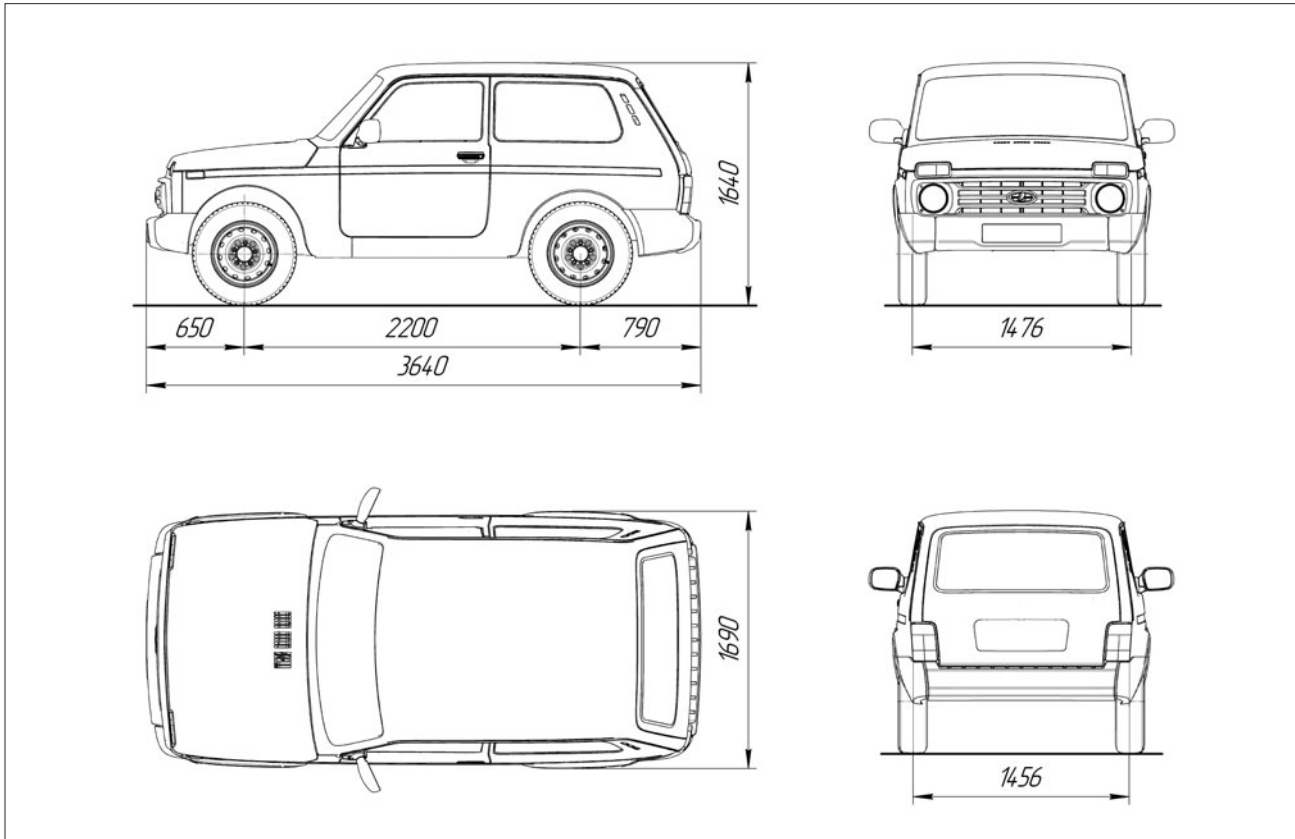

Fig. 33. Exterior dimensions for LADA 4x4 Urban

ATTENTION!

With mounted temporary spare wheel, which is with rim offset and differs from other wheels, in a vehicle running with speed above 80 km/h, stability and controllability get worse, which can lead to accident. After fixing of temporary spare wheel it is necessary to take measures for quick repair of standard wheel with cast disk and fitting it in a vehicle. Remember, that operation of vehicle with wheels having different rim offset and mounted to the same axle, forbidden by Traffic code.

A wheel with cast disk is not intended for housing under hood. It is forbidden to transport damaged wheel with cast disk on the storing place for spare wheel. During delivering of damaged wheel to repair station place it in rear trunk. After removal of spare wheel fasten the belts for wheel fixation in engine section, in order to avoid contact of belts with moving parts of engine.

WARNING!

Don't use nuts intended for stamped wheels for adjustment of cast wheels. Nuts intended for fitting of cast wheels have a thrust land. Such nuts are allowed for temporary wheel mounting.

Type and nominal amount of coolant in conditioner

Coolant (type/filled amount, kg).....R134 «A» / 0,4

Refit of fuses

Additional power consuming devices in LADA 4x4 Urban are protected by fuses, positioned in standard fuse panels. List of additional circuits is provided by Table 1. List of basic circuits is given in Operation Manual for LADA 4x4.

Table 1

ADDITIONAL CIRCUITS, PROTECTED BY FUSES

Fuse №	Protected circuit
Basic panel	
1 (16A)*	Front power windows. Side mirrors electric drive
2 (16A)**	Electric ventilator of climate control, conditioner compressor
9 (16A)*	Side mirror heaters
10 (16A)*	Central roof lighting
Additional panel	
15 (16A)*	Electric ventilator of climate control, conditioner compressor

* For LADA 4x4 URBAN.

** For LADA 4x4 with conditioner.

CAR MAINTENANCE AND ROUTINE REPAIRS

This section gives brief description of some types of activities on car maintenance and routine repairs.

Comprehensive process of maintenance, repair and disposal activities are available at LADA dealer enterprise which is also equipped with special equipment and tools. In view of this and to provide high quality maintenance work it is recommended to have the car serviced and repaired by LADA dealer. After thorough car washing regularly check condition of protective rubber boots of front wheel drive joints, spherical joints and also protective caps of steering link joints. Damaged or twisted boot or cap will cause ingress of dust, water and dirt to the joint which result in their early wear and destruction. Therefore, damaged

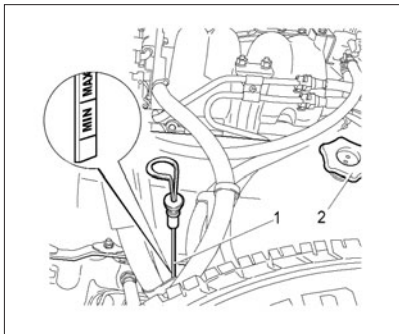

Fig. 34. Oil level check in crankcase

boot or cap must be replaced with a new one and adjust the twisted one.

In condition of permanent car operation in highly dusted areas air filter element must be changed two times as frequently as specified in the service book.

CRANKCASE OIL LEVEL

With the engine running, crankcase oil consumption is common phenomenon. Amount of oil consumed depends on driving style and defined by engine load and crankshaft rotational frequency. Oil consumption is somewhat higher in initial period of operation. Therefore, regularly, especially before long trips it is necessary to check oil level in the crankcase.

Oil level is checked when the engine is cold and not running, the car on a flat surface. The oil level must be between marks «MIN» and «MAX» of oil gage 1 (Fig. 34). Oil refilling, if necessary, is performed through filler closed with plug 2.

After refilling, oil level must be checked no earlier than in three minutes to allow the added oil portion drain to the crankcase.

For correct measuring of oil level insert oil gage 1 into locating hole as far as will go.

ATTENTION!

Excess of oil level in crankcase over «MAX» mark of oil gage 1 is inadmissible in order to prevent oil surge through crankcase ventilation system. Oil will hit combustion chamber and be discharged in the air with exhaust gases. In cars equipped with catalytic converters oil combustion products might put the catalyst out of operation.

COOLANT LEVEL

Coolant level must not be more than 40 mm higher than «MIN» mark applied on the semitransparent tank body (Fig. 35).

Level check and opening of tank plug for coolant replenishing is performed only with cold engine. After charging the tank with coolant the plug must be screwed home tightly to exclude ingress of dust.

ATTENTION!

To avoid burns do not open radiator plug of engine cooling system when cooling fluid is hot.

In cases when fluid level is constantly goes down and it has to be replenished, check cooling system for leaks and have the fault eliminated by LADA dealer.

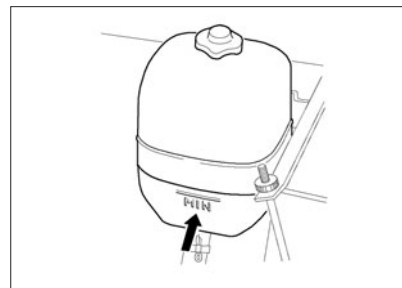

Fig. 35. Expansion tank

BRAKE FLUID LEVEL

Brake fluid level in combined tank 1 (Fig. 36) of brake and clutch hydraulic drive mounted on main brake cylinder is checked visually by marks applied on the tank body of semitransparent plastic. With removed cover 2, sensor 3 of brake fluid alarm level and new brake shoe pads the level of brake fluid must be at «MAX» mark. Upon fitting of cover 2 s and sensor 3 the level of brake fluid must be at lower edge of tank filler neck. If brake and clutch hydraulic drive is in good order, then fluid level drop in the tank is due to wear of brake shoe pads. Fluid level drop to «MIN» mark indirectly evidences their extreme wear. In this case it is necessary to check condition of pads rather than add brake fluid to the tank because with new brake shoes installed the level of fluid in the tank will rise to normal.

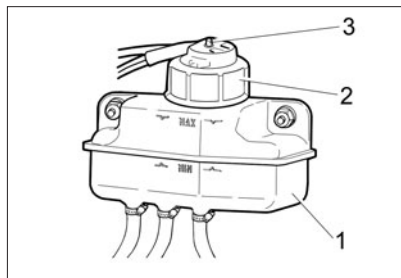

Fig. 36. Brake and clutch hydraulic drive tank

«Brake failure» indicator (refer to «Instrument cluster» section) is on when brake fluid level in the tank drops below «MIN» mark which, with partially worn or new shoe pads, is indicative of loss of tightness and fluid leak in the system. In this case replenish the fluid only after having system tightness restored by LADA dealer. With loss of tightness in clutch hydraulic drive «Brake failure» indicator is not switched on because separation of clutch hydraulic drive circuit and brake hydraulic drive circuit is performed above «MIN» mark. When checking brake fluid level in

the tank also do not miss to check proper operation of brake fluid alarm level sensor for which purpose press central part of sensor protective cap from above – in ignition switched off condition «Brake failure» indicator red light must be on in the instrument cluster.

During car operation give special attention to condition of flexible hoses as they are exposed to water, dirt, sand and salt. In case of minor cracks detected on hose outer coat or occurrence of swelling when applying brake pedal the hose needs to be replaced with a new one.

It is necessary to change brake fluid in the system after three years of operation because it absorbs moisture from environment which results in reduction of its boiling temperature. Moreover, water contained in the fluid may cause corrosion of parts of working brake system. When bleeding air from the brakes do not allow dropping of brake fluid level below «MIN» mark; when bleeding of air from clutch hydraulic drive do not allow dropping of brake fluid level to 15-17 mm below «MAX» mark.

WARNING!

Brake fluid is toxic! Therefore, it has to be stored in tightly closed containers and beyond the reach of children.

Do not allow ingress of brake fluid to body paint coating – this may damage the coating.

In option design version, a socket is provided for connection of extension lamp on the bracket of brake and clutch hydraulic drive tank.

HYDRAULIC POWER STEERING

To ensure proper operation of hydraulic power steering (installed ***in option design version***) it is necessary to check routinely fluid level in steering booster tank 2 (Fig. 37). With cold hydraulic pump, engine not running, fluid level must be between two notches of indicator in tank cover 1. Fluid level drop evidences system seal failure and needs mandatory checking and leak elimination at loose connection points which has to be performed by LADA dealer.

Noise from overflow valve operation may occur at steering wheel end positions. This is not a defect. Once the steering wheel is brought to middle position the overflow valve is switched off and the noise disappears.

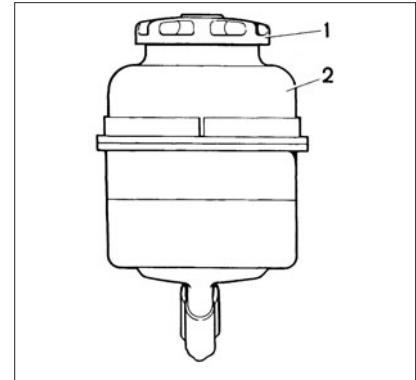

Fig. 37. Fluid level check in hydraulic power steering tank

WARNING!

Hydraulic power steering has been charged with Pentosin Hydraulik Fluid CHF 11S-TL VW52137.

When performing system maintenance and repair it is prohibited to use other fluids and mix them with the above fluid.

Elimination of faults and fluid refilling must be performed only by LADA dealer.

BATTERY ELECTROLYTE LEVEL

You should check the level of the electrolyte in the storage battery regularly. The electrolyte level must be between **MIN** and **MAX** marks (Fig. 38) on the semi-transparent battery case. It is prohibited to use battery when the electrolyte level is below the line with mark **MIN**.

If there are no **MIN** and **MAX** marks on the battery case, or if the battery case is opaque, then the electrolyte level should be 10-15 mm over the separators top border.

WARNING!

Due to the fact that the electrolyte is a corrosive fluid and its impact harmful for You and the vehicle components, it is advisable to carry out the storage battery maintenance at the certified SSNEs.

Do not let the battery run low and recharge it when necessary.

If the storage battery has electrolyte density and level indicator («spyhole»), then the battery status can be determined by its colour:

«Spyhole» is green – electrolyte level and density are normal;

«Spyhole» is black – it is necessary to charge the battery;

«Spyhole» is white – electrolyte level is too low.

If the battery has no «spyhole», the charging status can be determined by measuring voltage on battery terminals: voltage (with no load) must be not less than 12.6 V (which corresponds to 75% of charge at temperature 25°C).

You should regularly check the charging status of the storage battery in the following cases:

- If you use your car mostly for short city drives.
- If you use your car with ambient temperature below 0°C. Battery capacity decreases at low temperatures. In cold seasons switch on only those electric devices that are really necessary.
- If you plugged to the vehicle electric circuit any number of permanent electric consumer devices, e.g. clock or any other accessories installed at aftersales service.
- If your car is parked for a prolonged time. In this case it is recommended to disconnect the battery from the vehicle power system by disconnecting the clamps. If the ambient temperature is extremely

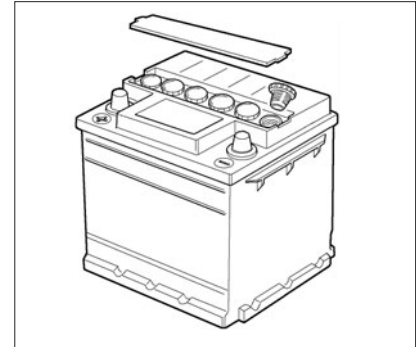

Fig. 38. Storage battery

low (below -30°C) it is recommended to dismount the battery from the vehicle and store it in a warm place.

ATTENTION!

Never remove the storage battery terminals with the ignition on, as this can cause errors in the EECS controller operation or lead to failures of electrical products.

Keep a continual watch on the cleanliness of terminals and storage battery clamps and check them for reliable connection. Remember that terminals and clamps corrosion as well as their poor connection can

cause sparking in the poor contact location, which can lead to the vehicle electronic equipment failure. Generator operability check by removing the storage battery clamps with the engine running is also not allowed.

During the storage battery installation in the vehicle, make sure that the wires are connected in accordance with the storage battery polarity indicated on their lugs and terminals (the positive terminal is bigger than the negative one).

During the storage battery charge directly in the vehicle, be sure to disconnect it from the vehicle power system.

SPARK PLUGS AND OTHER IGNITION SYSTEM ELEMENTS

Spark plugs do not require maintenance during time interval between replacements. Keep the plugs protected from impacts and mechanical damages. Additional replacement of plugs is allowable.

Keep high-tension wires clean and securely connected with spark plugs and ignition coil.

WARNING!

Disconnection and removal of high-tension wires from ignition system elements must be performed only by pulling at the protective cap. Wire removal by pulling at high-tension wire is prohibited.

WASHING FLUIDS

It is recommended to charge wash tanks of rear window, windscreen and headlamp with mixture of water and special glass detergent fluid specified in the mixture packing. Clean water may be used in warm season.

Before the next regular replenishment of windscreen and headlamp wash tank 1 (Fig. 39) check and clean, if necessary, filter mesh under cover 2.

For rear window glass washer, unscrew plug 1 (Fig. 40) of washer tank and add the fluid.

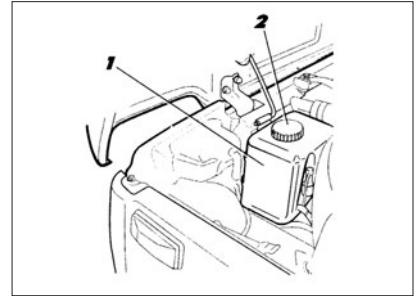

Fig. 39. Windscreen and headlamp washer tank

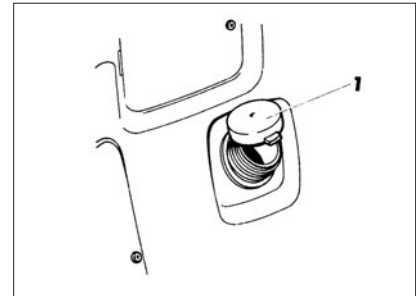

Fig. 40. Rear window glass washer tank

TIRE SERVICING

Regularly check tire pressure with a pressure gauge (refer to Table 2).

Operation of tires with air pressure differing from recommended value leads to their early wear, and also impairs car stability and drivability.

When continuous pressure drop is observed in the tire check for air leak through tire valve core (inside). In case of air leak tighten up the tire valve core, and if this does not solve the problem replace it with a new one.

If air pressure drops with a good valve core the tire needs repairing.

To avoid damaging of tire sealing layer perform its removal and mounting using special attachments or have it done by LADA dealer. To avoid wheel misbalance before flanging, make a mark on the tire with a chalk opposite the valve and then set the tire to this mark when mounting it.

After mounting of new tires be sure to have the wheels balanced by LADA dealer.

Table 2

TIRE PRESSURE

Tire sizes with load and speed capacity indices*	Wheel size		Tire pressure, MPa (kgf/cm ²)	
	rim width	rim overhang, (ET)**, mm	front wheels	rear wheels
Set by the manufacturer				
185/75 R16 92Q 95T	5J ***	58***	0,21 (2,1)	0,19 (1,9)
Admissible to set during operation				
175/80 R16 88Q	5J, 5 1/2J	48–58	0,21 (2,1)	0,19 (1,9)
195/70R15 92Q, T	5 1/2J, 6J	45	0,19 (1,9)	
205/70R15 95Q, S, T	6J, 6 1/2J	40	0,19 (1,9)	

* Speed indices: Q – up to 160 km/h, S – up to 180 km/h, T – up to 190 km/h.

Bearing capacity indices: 85 – 515 kg, 88 – 560 kg, 92 – 630 kg, 95 – 690 kg.

** Rim overhang (ET) – distance from disc mating (joint) face to rim center.

*** In operation, it is allowable to install wheels with rim width of 5 1/2J and ET of 48–58 mm.

Winter tires (M+S) of above oliminsions can be used with Q index with limited vehicle driving speed (<160 km/h).

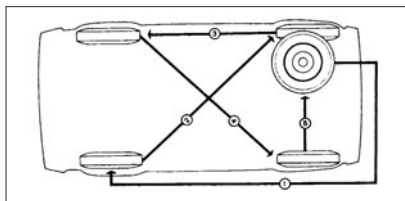

Fig. 41. Rotation pattern

To ensure even tire wear change the position of the wheels as shown in Fig. 41 following service book instructions. When driving the car avoid wheel rubbing against road curbs and driving fast on road with damaged pavement (bumps, pits, hollows etc.) as damaged rim might result in leakage of tubeless tires as well as its misbalance. In case of vibrations occurring during car movement check wheel balancing.

WHEELS CHANGING

ATTENTION!

If you have a puncture immediately replace the wheel.

The wheel replacement is a dangerous thing. The vehicle could fall off the jack and cause serious injury. Strictly follow the instructions.

Never get under the car, raised on the jack.

The jack is designed for the wheels replacement in case of emergency on the car Lada 4x4 (2121) only.

Before use, check the jack for damage.

You can use the jack for the vehicle standing in level position only.

For the wheels changing:

- pull the car off the road and place it on a level nonslip and stable ground. Put the car in reverse or the first gear, apply parking brake;

- activate the hazard light and set the alarm triangle;

- ask the passengers to leave the vehicle interior and stay away from the traffic area;

- prepare the jack, tools and replacement wheel;



Fig. 42. Lifting the car when replacing wheels

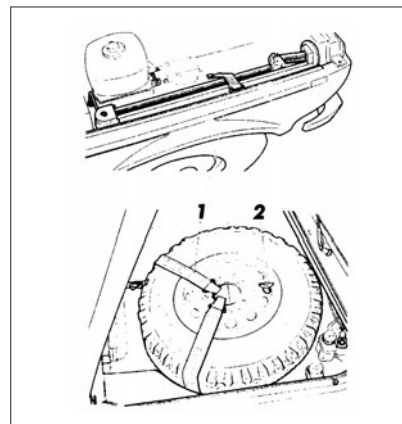

Fig. 43. Laying and fixing of jack and spare wheel

– slacken every wheel nut of the affected wheel one turn with the wheel brace 1 (Fig. 42); set the brace so that the force which applied to its arm, was down-directed;

– if the ground is soft, preset a strong pad (a piece of board) under the jack pad; insert the jack 3 completely in bracket 2 and turn the handle 4 until the wheel would be raised a few inches above the bearing area;

– fully unscrew the wheel nuts and lift the wheel;

– fit the spare wheel and tighten the wheel nuts uniformly;

– lower the vehicle and remove the jack;

– tighten the wheel nuts uniformly, check and top up the tire pressure;

– stow the jack and the replaced wheel into the car, as shown in Fig. 43, and fasten them with elastic straps 1. Fix the wheel with the screw 2;

– address to the nearest service station to check wheel nuts tightening and repair (if possible) of the damaged tire.

RECOMMENDATION

After 50 kilometers tighten the wheel nuts with the required torque.

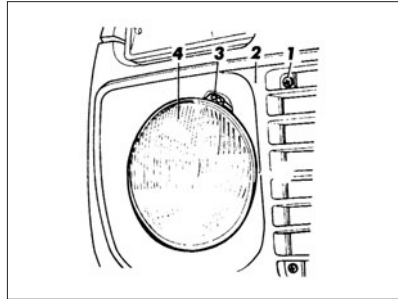

Fig. 44. Lamp

Improperly tightened nuts can cause the wheel wobbling, and at worst – loosening, which could lead to an accident.

NOTE

Jack can't be disposed of in the trash, it can be utilized with your car or be driven it to a local receiving point for scrap.

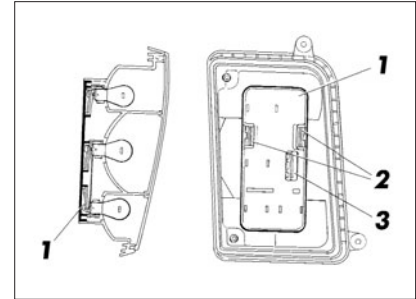

Fig. 45. Rear light

REPLACING LAMP

When replacing lamps use lamps specified in Appendix 2. To replace a lamp in the headlamp, remove screws 1 (Fig. 44) retaining decorative facing 2 of radiator and remove the facing, loosen retaining screws 3 of optic element rim, turn the rim anticlockwise and remove it. Remove optic element 4, remove the block, move spring catch tongues out of slots and remove the lamp.

To replace a lamp in the rear light, remove a plastic plug on the inside of luggage compartment, detach the block from socket 3 (Fig. 45),

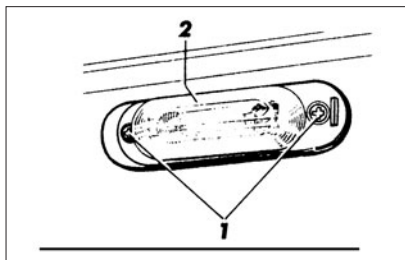

Fig. 46. Licence plate light

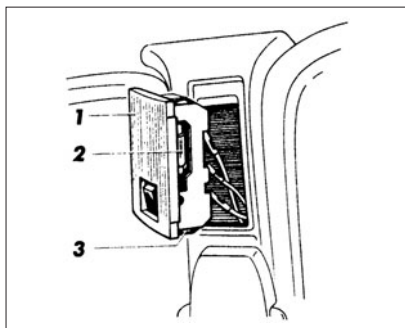

Fig. 47. Interior light

squeeze catches 2 of base 1 and remove it in assembly with lamps. Then push the lamp down, turn it anticlockwise and remove from the socket.

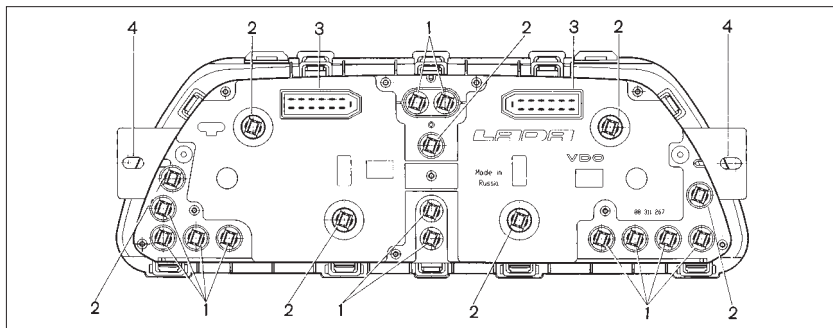

Fig. 48. Instrument cluster

To replace a lamp in the licence plate light, it is necessary on the inside of licence plate pad push down the cover with LADA 4x4 and precisely, overcoming resistance of plastic snaps, remove it. Then, through holes in licence plate pad remove light retaining screws 1 (Fig. 46), take the light out of the socket and remove the lens 2. To replace burned-out lamp 2 (Fig. 47) in interior light 1, smoothly pull it on. The interior light is retained in B-pillar groove with two springs 3. To replace the lamp in the front light turn the receptacle anticlockwise on engine bay side and remove it, push

the burned-out lamp down, turn anticlockwise and remove it from the receptacle.

A burned-out light bulb in side turn indicator is replaced after removing receptacle with the lamp on engine bay side.

To replace indicating lamps 1 (Fig. 48) and lamps 2 of instrument cluster lighting remove the board and screws retaining it at eyes 4. Then pull on the instrument cluster and disconnect wire harnesses from blocks 3. Turn the bulb to be replaced anticlockwise and take it out from the receptacle.

REPLACEMENT OF FUSES

The fuses are inserted in two blocks (Fig. 49) and retained in them with spring contacts. Circuits protected with them are specified in table 3.

In case of repeated burnout of a fuse apply to LADA dealer for troubleshooting to investigate what caused its fusing.

Installing a homemade jumper or a fuse of a different current rating in replacement of a burned-out fuse is prohibited.

Fused are not designed to protect circuits of ignition, engine starting, alternator (except for drive winding), dimlight relay, high beam relay.

Cars with ECU have an additional block of fuses (Fig. 50) on left side frontage under instrument panel to protect fuel injection elements. A faulty fuse is detected via out-of-work circuits protected with it, according to 4.

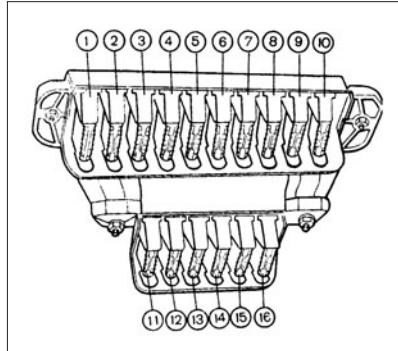

Fig. 49. Fuses

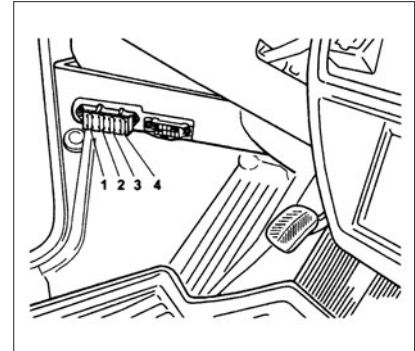

Fig. 50. Additional fuses

CIRCUITS PROTECTED WITH FUSES

Fuse No.	Circuit protected
Main block	
1 (16A)	Heater fan electric motor Rear window defrosting relay (winding) Electric motors of rear window wiper and washer Windscreen washer electric motor
2 (8A)	Windscreen wiper relay and electric motor Turn indicator lamp and flasher and emergency signaling (in turn indicating mode) Turn indicators signaling lamp Rear lights (reversing light lamps) Alternator exciting winding (at engine start) Signaling lamp of differential locking in transfer case Parking brake signaling lamp Signaling limp of working brake system emergency state Insufficient oil pressure signaling lamp Engine cooling system temperature gage Fuel-level gage with fuel reserve check lamp Charge control lamp Tachometer
3 (8A)	LH headlamp (high beam) High beam indicator lamp
4 (8A)	RH headlamp (high beam)
5 (8A)	LH headlamp (dimlight)
6 (8A)	RH headlamp (dimlight)
7 (8A)	LH side light (marker light) LH rear light (marker light) Licence plates lights Signaling lamp of marker light turnon
8 (8A)	LH side light (marker light) LH rear light (marker light) Instrument illuminating light Heater control arms highlighting Cigarette lighter light lamp Spotlamps of switches

Table 3 continued

Fuse No.	Circuit protected
9 (16A)	Turn indicators and flasher or turn indicators and emergency signaling in emergency signaling condition Rear window heating element and its switching relay (contacts)
10 (16A)	Motor horn (auto-alarm) Interior lighting bulb bowls Rear lights (stop-lamps)
Additional block	
11 (8A)	Backup
12 (8A)	Backup
13 (8A)	Foglamps, rear foglight relay
14 (16A)	Cigarette lighter
15 (16A)	Backup
16 (8A)	Backup

Table 4

Fuse No.	Circuit protected
1 (7,5A)	Control unit
2 (15A)	Electric fuel pump relay (contacts) Electric fuel pump
3 (15A)	Main relay
4,5 (30A)	Electric fans relay (winding) (RH, LH) Electric motors of electric fans (RH, LH)

BODY

The body represents a basic and the most expensive car element. It is fabricated from advanced materials and corrosion-protected with high-end protection means. Basis for anti-corrosion protection life has been set by the manufacturer; however, paint coats and other protective coating are susceptible to natural ageing and wear. Effectiveness of anticorrosion protection and its durability depend on climatic, environmental, operation, storage, maintenance and care conditions and timeliness of preventive measures taken.

Avoid excessive forces applied or uncontrolled movements of doors, bonnet and trunk lids leading to damages and/or attritions of doors and body for which the manufacturer is not held responsible. To avoid scratches appearing on body paint

coating do not remove dust and dirt with dry wiping material. It is recommended to wash the car with low head water jet before the dirt gets dry with the use of a soft sponge and applying automotive washing shampoos which form films protecting the surface against environmental exposures.

ATTENTION!

Do not wash the car with soda and alkaline solutions nor with waste/sewage waters or other fluids not designed for car washing.

Fix the drains of doors and sills before car washing.

ATTENTION!

Due to variety of jet washer brush unit designs available on the servicing market car wash with brush jet washers may lead to loss of paint coating glossiness and impairing of its protective properties. Therefore, it is advisable that you preliminarily inquire washing machine operator about

design, technical condition of brushes and severity of your car paint coating exposure to washing.

In summer wash your car in the open air and in the shade. If it is impossible wipe the washed and wet surfaces dry immediately after washing as water drops form stains on painted surface when drying out in the sun. In winter, after washing the car in a heated space wipe dry the car body and seals before driving out as freezing of remaining drops might form cracks on paint coat and freezing-in of seals to body.

ATTENTION!

Do not wash the car with ignition switched on.

When washing the car avoid direct water jet hitting electric equipment parts, electronic devices, sensors and connectors in the engine bay. Look after condition of protective boots covering detachable connections of electronic blocks and sensors. In case of moisture ingress

blow the connectors with compressed air and treat them with repellent to protect contacts from oxidizing.

Carefully wash hemming areas of doors, bonnet, trunk lid, weld seams and connections of engine bay, trunk and door openings as dirt accumulated in these locations will lead to destruction of protective-decorative coating and corrosion of metal.

ATTENTION!

When signs of corrosion appear (including those in weld seams and joints) and also deterioration of paint coat (splits, scratches, abrasions) and other protecting coatings (splitting and abrasion of seal and primer) it is necessary to apply to LADA dealer to take actions toward elimination of further corrosion development, restoration and repair of paint and protective coatings.

Timely taken measures against corrosion process developing on the body and other car parts will extend its life and keep vendibility

for long. If you fail to take timely measures to eliminate corrosion processes on the body the manufacturer bears no responsibility for further body condition of your car.

To enhance corrosion resistance of the body special anticorrosion agent is applied in closed box-type hollows of sills, longitudinal members, crossmembers and other underbody elements. During car operation it is necessary to have the body provided with anticorrosion treatment by LADA dealer during the first year of operation and routinely once a year following a process developed by the manufacturer.

ATTENTION!

Exhaust system must be checked after body treatment with anticorrosion agent by LADA dealer (catalyst, main and auxiliary muffler) for absence of residual agent on the above mentioned parts to prevent inflammation.

In the course of car operation under body coating and paint coat on front and rear lower fenders is exposed to abrasive wear caused by gravel, sand and salt. This exposure results in abrasion of seal and primer, bear metal surfaces get rusty. Therefore, routinely check condition of coatings and timely restore damaged areas.

To keep painted surfaces glossy (especially for the cars laid up in the open air) regularly polish them with polishing pastes. These pastes cover micro cracks and pores appearing in paint coating during car operation which prevents corrosion occurrence under paint layer.

To keep body surface shiny for long, do not leave the car continuously exposed to the sun and also avoid exposure body surface to acids, soda solutions, brake fluid and gasoline.

To prevent stains forming on the paint coating under fuel tank cover after ingress of gasoline wipe the surface of with clean rags before and after refueling. In view of bad environmental situation in some regions there are cases of aggressive action

of individual components of environment on car protective-and-decorative coatings. These attacks are evident as rust-coloured scatter, local colour variation of paint top coats, local deterioration of body enamel coating. Rust-coloured scatter occurrence is caused by deposition of minute particles of metal dust suspended in the air on horizontal body surfaces which gets stuck to the body with corrosion products during moistening with dew. Rust-coloured scatter can be removed with 5% solution of ethane diacide with addition of a detergent and copious subsequent washing with clean water.

Local colour variations (stains) of pain top coat and local deterioration of body enamel coating result from exposure to acid industrial discharges after their compounding with air moisture. Such attacks are eliminated, depending on severity, by polishing or repainting of the body.

Wipe plastic parts with damp rags. To use gasoline or solvent for this is prohibited as plastic part will lose gloss.

CAR LAYING-UP

During car operation give much attention to car storage conditions. The most optimal conditions for car storage are:

- vehicle shed where temperature and humidity correspond to environmental parameters, continuous air movement is available and the car is not exposed to insolation and precipitations;

- heated space (individual garage) with temperature no lower than 5 °C and relative humidity of 50%, equipped with suction-and-exhaust ventilation.

But if a heated space (individual garage) has poor suction-and-exhaust ventilation while the car is used in winter period or laid up after washing without preliminary drying, this will multiply destructive effect on decorative coatings/covers/trims.

When laying-up the car in vehicle shed for winter you should remove the battery and store it separately; drain water from window washer tanks.

When preparing the car to laying-up for long period:

1. Wash the car and wipe the body dry. Apply preservative on the body.

2. Discharge the battery completely.

Car maintenance during laying-up (one or two times a month) amounts to the following: start and run the engine for 1-2 minutes having taken care about exhaust venting, check operation capability of the systems and signaling devices, turn the engine off.

CAR PERFORMANCE DATA

MAIN PERFORMANCE PARAMETERS AND DIMENSIONS

Parameters	Car model and its versions	
	VAZ-21214	VAZ-2131
Body type	All-metal, unitized, three-door, station wagon	All-metal, unitized, five-door, station wagon
Layout scheme	All-wheel-drive, with engine longitudinal arrangement	
Number of seats, pers	4	5
Number of seats with backseats folded, pers	2	2
Unladen mass, kg	1210	1370
Authorized maximum weight (PMM), kg	1610	1870
Road clearance at PMM with statistics tire radius of 314 mm (185/75R16), no less than, mm: – up to front suspension crossmember – up to rear axle beam	221 213	
External minimum radius of turn at front wheel track center line, m	5,5	6,45
Full mass of trailer towed*, kg: – without brakes – equipped with brakes	300 600	
Overall dimensions, mm	Fig. 51	Fig. 52

* This being the case, vertical load applied to towing coupler ball must be within 25–50 kg range.

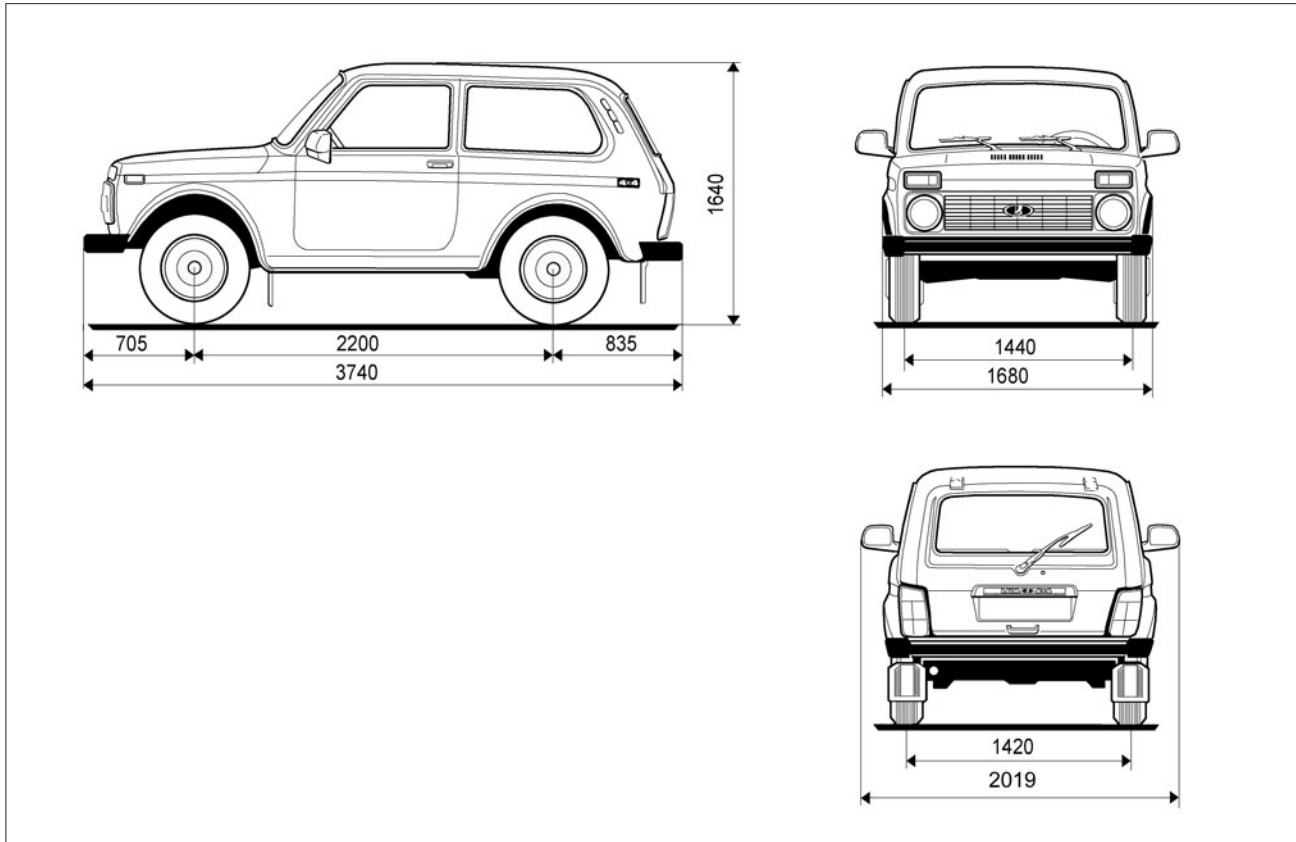

Fig. 51. Overall dimensions of VAZ-21214 car model and its versions

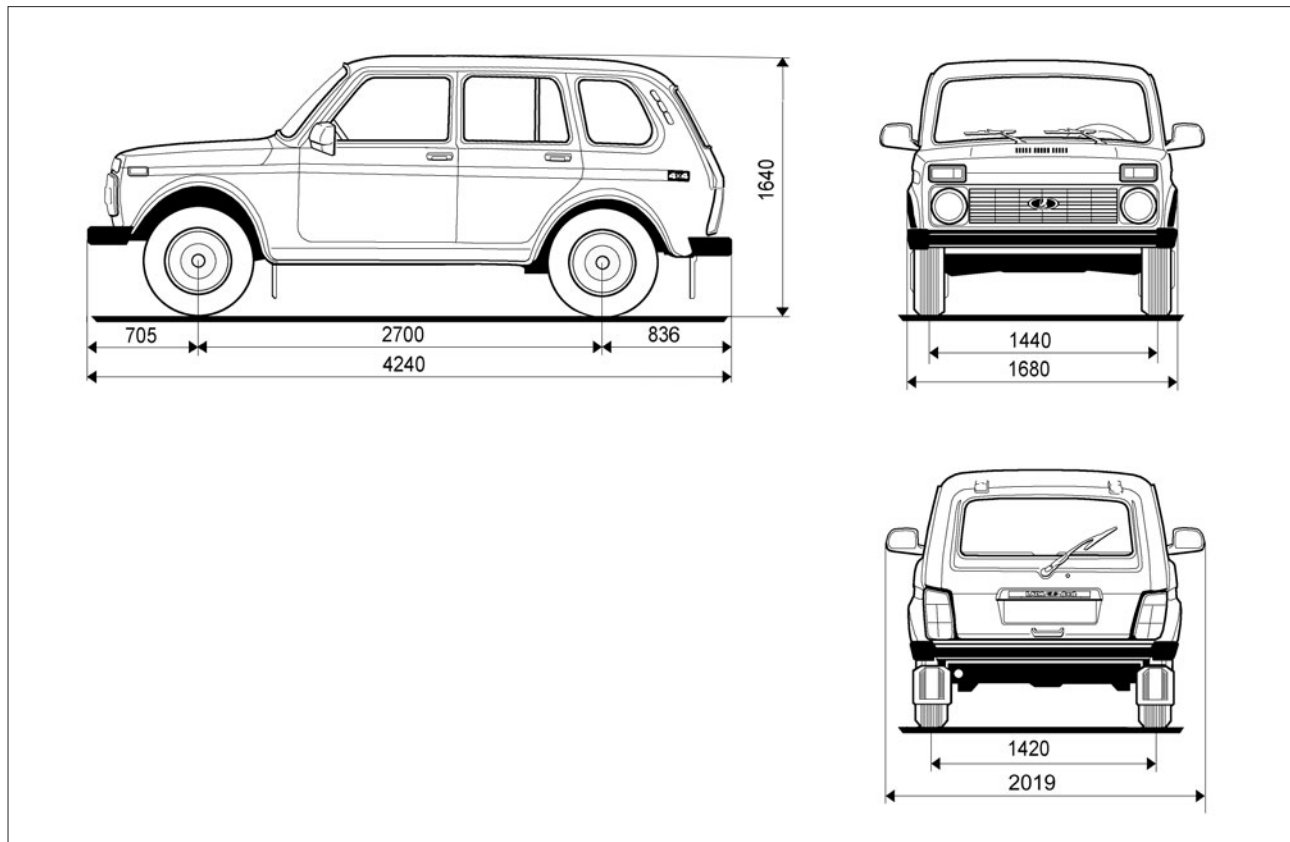

Fig. 52. Overall dimensions of VAZ-2131 car model and its versions

MAIN ENGINE PARAMETERS

Performance indicators	Engine
	VAZ-21214-10
Engine type	4-cylinder, in-line, 4-stroke
Engine displacement, L	1,69
Cylinder diameter and engine stroke, mm	82x80
Compression ratio	9,3
Maximum power to GOST 14846 (net value), kW	59,5
Engine rotational frequency at maximum power, min ⁻¹	5000
Minimal engine rotational frequency, min ⁻¹	850 ± 30
Fuel/ignition system	Electronic engine control unit (ECU) (MPFI)

CAR FUEL AND SPEED PERFORMANCE DATA

Car model	Engine model	Maximum speed*, km/h	Acceleration time* to 100 km/h, s	Fuel consumption in combined cycle**, L/100 km
VAZ-21214	VAZ-21214	142	17,0	10,8
VAZ-2131	VAZ-21214	137	19,0	10,8

* measured to specific methods.

** obtain in tests to EEC 93/116 and 99/100 Directives on dynos. Serves for comparison of different cars only and does not represent standard good operation practice.

CHARGE VOLUMES

System charged	Volume, L
Fuel tank (including reserve)	42 (65*)
Engine cooling system (including interior heating system)	10,7
Engine lubrication system (including oil filter)	3,75
Gearbox case	1,6
Rear-axle housing	1,3
Steering gear housing	0,18
Transfer case	0,79
Front-axle housing	1,15
Clutch hydraulic drive system	0,2
Brake hydraulic drive system	0,535
Windscreen and headlamp washer tank	2,8
Rear window washer tank	2,0
Hydraulic power steering tank	1,7

* For VAZ-2131 cars and its versions.

PASSPORT DETAILS

A plastic identification (factory) plate is installed on the vehicle (Fig. 53). The numbers on plastic plate shall be read as follows:

- 1 – vehicle designation;
- 2 – engine designation;
- 3 – spare parts number;

(Number for spare parts corresponds to progressive sequence number.

When ordering spare parts it is necessary to use the information containing on identification (factory) plate.)

- 4 – manufacturer;
- 5 – EEC type-approving certificate number;

6 – identification number (VIN);

(Identification number is decoded as follows: first three letters according to international standards are the code of manufacturer-plant; six following numbers or Latin letters – car model; the following number or Latin

letter – represents the model year; last seven numbers – chassis number, for passenger car it corresponds to body number. According to technical requirements «On wheeled transport safety» model year is defined as a conventional year indicated by the manufacturer. In JSC AVTOVAZ the model year starts from July, 1 of calendar year. So, in the period from January, 1 till June, 30 the model year corresponds to actual year of manufacture, and beginning from July, 1 till December, 31 corresponds to the following year.

VIN is also stamped on the right-hand telescopic strut.)

7 – technically permissible max. gross weight of vehicle;

8 – technically permissible max. gross weight of truck and trailer;

9 – technically permissible maximum permissible load on front axle;

10 – technically permissible maximum permissible load on rear axle.

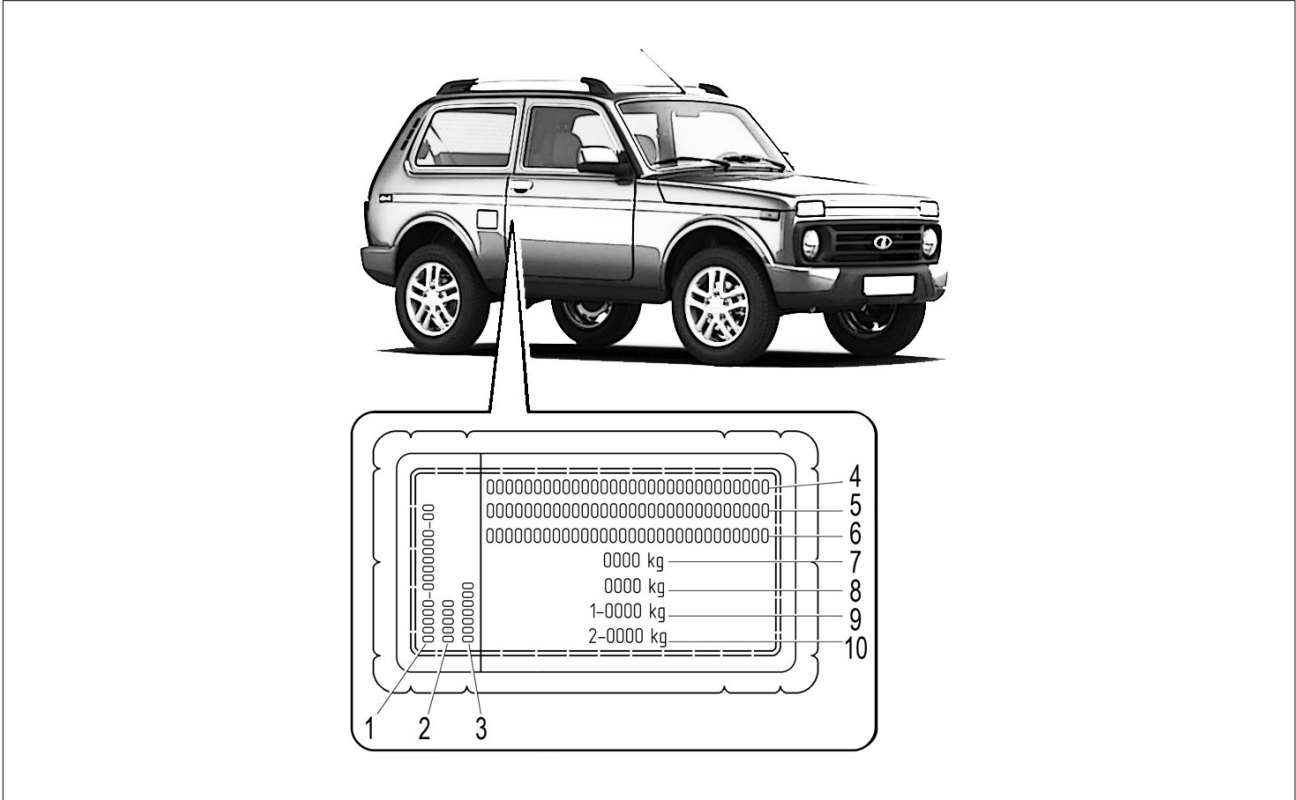

**Fig. 53. Passport details. Installation site of name plate:
21214 – Side panel, RH; 2131 – Side panel middle, RH**

APPENDICES

Appendix 1

OIL AND LUBRICANTS VALIDATED AND RECOMMENDED FOR OPERATION OF LADA 4X4 CAR AND ITS VERSIONS

MOTOR GASOLINES

Table 1

Recommended gasoline grade
«Premium Euro-95» GOST R 51866

Notes:

1. To ensure engine start and car operation at low ambient air temperatures appropriate volatility class gasoline is to be used depending on a climate region. Requirements to volatility classes and seasonal application of gasoline grades for different regions of Russian Federation are set forth in relevant standards for combustion engine fuels.

2. It is impermissible to use gasoline grades with metal-organic antiknock agents on the basis of lead, ferrum, manganese and other materials.

3. There is no need to use supplementary additives as in particular cases this might cause damage of engine and car systems.

Independent admixture of secondary additives by car owner is not recommended and may initiate early termination of warranty validity for some car parts and units.

ENFINE OILS

Table 2

Oil grade	Viscosity class to SAE	Group		Manufacturer	Regulatory Document
		AAI	API		
LUKOUL LUX	15W-40	B5/D3	SL/CF	LLC «LLK-INTERNATIONAL» JSC «Lukoil»	STO 00044434-003
LUKOUL LUX synthetic	5W-30, 5W-40 10W-40	B5/D3	SL/CF	LLC «LLK-INTERNATIONAL» JSC «Lukoil»	STO 00044434-003
LUKOUL LUX synthetic	5W-40, 5W-30	B6/D3	SN/CF SL/CF	LLC «LLK-INTERNATIONAL» JSC «Lukoil»	STO 00044434-003
ROSNEFT MAXIMUM	5W-40, 10W-40	B5/D3	SL/CF	JSC «Novokuibyshevsk plant of oils and additives», Novokuibyshevsk	TU 0253-063-48120848
ROSNEFT MAXIMUM	5W-40, 10W-40	B5/D3	SL/CF	JSC «Angarskaya Neftechimicheskaya Kompania», city of Angarsk	TU 0253-391-05742746
ROSNEFT PREMIUM	5W-40	B6/D3	SM/CF	JSC «Angarskaya Neftechimicheskaya Kompania», city of Angarsk	TU 0253-391-05742746
THK MAGNUM SUPER	5W-30, 5W-40 10W-40, 15W-40 15W-50	B5/D3	SL/SJ/CF	LLC «THK Lubricant materials» city of Ryazan	TU 0253-008-44918199 TU 0253-025-44918199
EXTRA	5W-30, 10W-40 15W-40	B5/D3	SL/CF	LLC «Gaspromneft-SM», «Omsk plant of lubricant materials», Omsk	TU 38.301-19-137
G-ENERGY S SYNTH	10W-40, 15W-40	B5/D3	SL/CF	LLC «Gaspromneft-SM»	
G-ENERGY EXPERT L	5W-30, 5W-40 10W-40	B5/D3	SL/CF	LLC «Gaspromneft-SM»	STO 84035624-034
ESSO ULTRA	10W-40	B5/D3	SL/SJ/CF	Exxon-Mobil Corporation, USA	

Table 2 continued

Oil grade	Viscosity class to SAE	Group		Manufacturer	Regulatory Document
		AAI	API		
GT TURBO SM	10W-40	B5	SM	Hanval INC, Korea	
MOBIL 1 ESP FORMULA	5W-30	B6/D3	SN/SM/CF	Exxon-Mobil Corporation, USA	
MOBIL 1 NEW LIFE	0W-40	B6/D3	SN/SM/SL/SJ/CF	Exxon-Mobil Corporation, USA	
MOBIL 1 PEAK LIFE	5W-50				
MOBIL SUPER 3000 X1	5W-40				
MOBIL SUPER 2000 X1	10W-40	B5/D3	SL/SJ/CF	Exxon-Mobil Corporation, USA	
SHELL HELIX PLUS	10W-40	B5/D3	SL/CF	Shell East Europe Co, Great Britain	
SHELL HELIX PLUS EXTRA	5W-40	B6/D3	SM/CF		
SHELL HELIX ULTRA	5W-40	B6/D3	SM/CF		
SHELL HELIX HX7	5W-40	B6/D3	SM/CF	Shell East Europe Co, Great Britain	
SHELL HELIX HX8	10W-40				
	5W-40				
ZIC A PLUS	5W-30, 10W-30 10W-40	B5	SL	SK Corporation, Korea	

Note. Oil change frequency is subject to car service book.

ENGINE OIL APPLICATION

Table 3

Min engine cold start temperature, °C	Viscosity class to SAE J 300	Maximum ambient temperature, °C
below -35	0W-40	30
-30	5W-30	25
-30	5W-40	35
-25	10W-30	25
-25	10W-40	35
-20	15W-40	45
-15	20W-50	over 45

**TRANSMISSION GEAR OIL GRADES TO BE APPLIED IN GEABOX, TRANSFER BOX,
DRIVING AXLES AND STEERING REDUCER GEAR**

Table 4

Oil grade	Viscosity class to SAE	Group for API	Manufacturer	Regulatory document
LUKOIL TM-5	75W-90 80W-90 85W-90	GL-5	LLC «LLK-INTERNATIONAL» JSC «Lukoil»	STO 00044434-009
ROSNEFT KINETIC	75W-90 80W-90 85W-90	GL-5	JSC «Angarskaya Neftehimicheskaya Kompania», Angarsk	TU 0253-394-05742746
ROSNEFT KINETIC	75W-90	GL-5/4	JSC «Novokuibyshevsk plant of oils and additives», Novokuibyshevsk	TU 0253-030-48120848
ROSNEFT KINETIC	80W-90 85W-90	GL-5	JSC «Novokuibyshevsk plant of oils and additives», Novokuibyshevsk	TU 0253-030-48120848
THK TRANS GIPOID	80W-90 85W-90	GL-5	LLC «TNK Smazochnye Materialy», city of Ryazan	TU 38.301-41-196
THK TRANS GIPOID SUPER	75W-90	GL-5	LLC «TNK Smazochnye Materialy», city of Ryazan	TU 0253-014-44918199
G-ENERGY BOX EXPERT	75W-90 80W-90	GL-5	LLC «Gazpromneft-SM»	STO 84035624-040
SHELL SPIRAX S5 ATE (SHELL TRANSAXLE OIL)	75W-90	GL-5/4	Shell East Europe Co, Great Britain	

RECOMMENDED TEMPERATURE RANGES FOR APPLICATION OF TRASMISSION OILS

Table 5

Min temperature ensuring lubrication of units, °C	Viscosity class to SAE J 306	Maximum ambient temperature, °C
-40	75W-80	35
-40	75W-85	35
-40	75W-90	45
-26	80W-85	35
-26	80W-90	45
-12	85W-90	45 and higher

ATTENTION!

Do not use oil additives or other means to enhance operation of engine, its systems and car transmission.

Up-to-date high-performance engine and transmission oil grades are recommended to use for the car operation. Therefore, using further additives is not necessary, moreover, in particular cases this might lead to such engine and transmission that are not covered by AVTOVAZ warranty.

COOLANTS

Table 6

Fluid grade	Manufacturer	Regulatory document
Compatible coolants coloured blue or green		
TOSOL-TS FELIX	LLC «Tosol-Sintez», Dzerzhinsk	TU 2422-006-36732629
Cool Stream Standard	JSC «Technoform», Klimovsk, Moscow Region	TU 2422-002-13331543
G-Energy Antifreeze	JSC «Technoform», Klimovsk, Moscow region	TU 2422-002-13331543
Compatible coolant fluids coloured red		
ANTIFREEZE SINTEC	CJSC «Obninskorgsintez», Obninsk	TU 2422-047-51140047
Cool Stream Premium	JSC «Technoform», Klimovsk, Moscow Region	TU 2422-001-13331543
FELIX CARBOX	LLC «Tosol-Sintez», Dzerzhinsk	TU 2422-068-36732629

Note. Brake fluid service life and replacement is subject to car service book.

BRAKE FLUIDS

Table 7

Fluid grade	Manufacturer	Regulatory document
ROSDOT	LLC «Tosol-Sintez», Dzerzhinsk	TU 2451-004-36732629
KAPROS-DOT	LLC «Sibur-Neftehim», Dzerzhinsk	TU 2451-030-52470175

Note. Brake fluid service life and replacement is subject to car service book, but no longer than three years.

GLASS WASH FLUIDS

Table 8

Fluid grade	Manufacturer	Regulatory document
OBZOR-Э	LLC «ASD», Togliatti	TU 2421-001-55894651
OBZOR	AOOT «Orsknefteorgsintez», Orsk	TU 38.302-20-20
ISKRA	NPP «Macromer», Vladimir	TU 2451-007-10488057
CHISTAYA MILYA 40	LLC «Tosol-Sintez», Dzerzhinsk	TU 2384-071-36732629

VISCIOUS (GREASE) LUBRICANTS

Table 9

Material grade	Manufacturer	Regulatory document
Technical petroleum jelly VTV-1	JSC «Rikos», Rostov-on-Don city	TU 38.301-40-21
Technical petroleum jelly ONMZ VTV-1	JSC «Neftemaslozavod», Orenburg	TU 0255-195-05767887
LITOL-24 grease	JSC «Azmol», Berdyansk	GOST 21150
LITIN 2	LLC «PKF «RUSMA», Saint Petersburg	TU 0254-311-00148820
Agrinol LSC-15 grease	LLC «TPK «Agrinol», Berdyansk	TU U 23.2-30802090-069
UNIROL-1 grease	JSC «Rikos», Rostov-on-Don city	TU 38.301-40-23
AZMOL LSC-15 grease	JSC «Azmol», Berdyansk	TU U 23.2-00152365-180
UNIOL-2M/1 grease	JSC «Azmol», Berdyansk	TY 38.5901243
AZMOL FIOL-1 grease	JSC «Azmol», Berdyansk	TU U 23.2-00152365-173
AZMOL ShRB-4 grease	JSC «Azmol», Berdyansk	TU U 23.2-00152365-172
AZMOL ShRUS-4 grease	JSC «Azmol», Berdyansk	TU U 23.2-00152365-182
ShRUS-4 grease	JSC «Rikos», Rostov-on-Don city	TU 0254-001-05766706
ShRUS-4M grease	JSC «Perm coolant and lubricant plant», city of Perm	TU 38.401-58-128
Ortol Sh grease	JSC «Neftemaslozavod», Orenburg	TU 0254-166-05767887
Lubricating graphite «P»	LLC «TPK «Agrinol», Berdyansk	GOST 8295

BODY ANTICORROSION TREATMENT MATERIALS

Table 10

Material grade	Purpose
Mercasol-845 AL, Mercasol-847 AL	Seal (mastic) for protection of body underside and wheel arches
Tectyl 231-UR Zinc UBC	
Mercasol-Non-Drip Transparent, Mercasol-831 ML, Mercasol 917 Non Drip Brown, Mercasol-ML Transparent	Seal (mastic) for protection of closed body cavities
Tectyl 654-CR Zinc ML	

HYDRAULIC POWER STEERING CHARGE FLUID

Table 11

Material grade	Manufacturer	Regulatory document
PENTOSIN CHF 11S	Pentiosin Werke AG, Germany	TTM 1.97.0964-2004

LAMPS USED IN THE CAR

Mounting location	Type designation	
	international	Russian
Headlamp*	H4	AKГ 12-60+55
Front lights*:		
– turn indicator	P21W	A12-21-3
– marker light	R5W	A12-5
Rear lights*:		
– brake light	P21W	A12-21-3
– marker light	T4W	A12-4
– turn indicator	P21W	A12-21-3
– reversing light	P21W	A12-21-3
– fog light	P21W	A12-21-3
Side turn indicators*	T4W	A12-4
Licence(number) plate light*	C5W	AC12-5
Car interior lighting	C5W	AC12-5
Cigarette lighter socket lighting		A12-4
Instrument cluster lighting		AH12-1,2
Instrument cluster check lamps		AH12-1,2
Alarm signaling turn-on check lamp		A12-08-1
Spot lamps		A12-1,2

ATTENTION!

*** Car head lamps and light-and-signal devices have been homologated (denoted with character «E») for conformity of light and colour performance and light sources applied (bulbs) to international safety requirements. Application of other light sources than those specified might lead to impairing of operation of these devices and violation of safety regulations.**

**List of parts containing precious metals used
in LADA 4x4 car**

Part reference number	Product description	Precious metal location	Weight, g		
			gold	silver	palladium
2115-3801010	Instrument cluster	In semiconductors	0,000263	0,016414	
2105-3709310/-01	Three-arm switch	Coating		0,1664	
2101-3704010-11	Ignition switch	In contacts		0,14078	
2105-3710010-03/-04	Alarm signaling switch	In contacts		0,107	
21213-3709607	Antifrost screen switch	In contacts		0,11517	
2113-3709609-10	Rear foglight switch	In contacts		0,115169	
2104-3709612	Rear screen wiper and washer switch	In contacts		0,403093	
2107-3709608-01	Heater-motor switch	In contacts		0,265997	
21045-3709280	Fuel heatup switch	In contacts		0,170288	
2108-3720010-10/-11/-12	Brake signal switch Alternator voltage regulator	In contacts In semiconductors	0,0534	0,1681	
2106-3828110	Water temperature gauge switch	In contacts		0,0161637	
2105-3747010-02/03	Turn indicator and alarm signaling break-in relay	Gold in semiconductors, silver in contacts	0,00021	0,0731	
2105-3747210-12	Headlamp high beam relay	In contacts		0,055	
2105-37470-1010-12	Dimlight relay	In contacts		0,055	
2105-3747210-02	Headlamp clean relay	In contacts		0,137	
2114-3747610	Rear foglight relay	Gold in semiconductors, silver in contacts	0,000998	0,034935	
2107-3747710	Wiper relay		0,00023	0,105	-
2112-3851010-00	Coolant temperature sensor	Thermo resistor	-	0,008284	-
2112-3855020-01	Nock sensor		-	0,05	-

Spark plugs*

Engine type	Spark plug type
8-valve engine	A17ДBPM OAO Robert Bosch Saratov LR15YC-1 BRISK WR7DCX Bosch

* Gap between spark plug electrodes must be within limits of 1...1,15 mm.

Автомобиль LADA 4x4 и его модификации

Руководство по эксплуатации на английском языке
(состояние на 09.02.2016 г.)

ДТР ОАО «АВТОВАЗ»

Разработчики: *Ю.В.Сабанов, Н.В.Казаков, А.В.Мингачев*

Художник: *Е.И.Брейкин*

Корректор *Н.С.Фомина*

Компьютерная верстка *Т.В.Лисина*

Формат 60x90¹/₁₆. Объем 5 п.л. Заказ 195. Тираж 200.
Отпечатано ООО «Двор печатный АВТОВАЗ». Март 2016 г.

21213-3902021-11
АНГЛИЙСКИЙ ЯЗЫК